

TM 55-1945-205-24-3-4

TECHNICAL MANUAL

UNIT, DIRECT SUPPORT AND GENERAL SUPPORT
MAINTENANCE MANUAL
FOR

MODULAR CAUSEWAY SYSTEM (MCS)
WARPING TUG (WT) TRANSFER CASE

738AN4NL4F

NSN 2040-01-505-2036

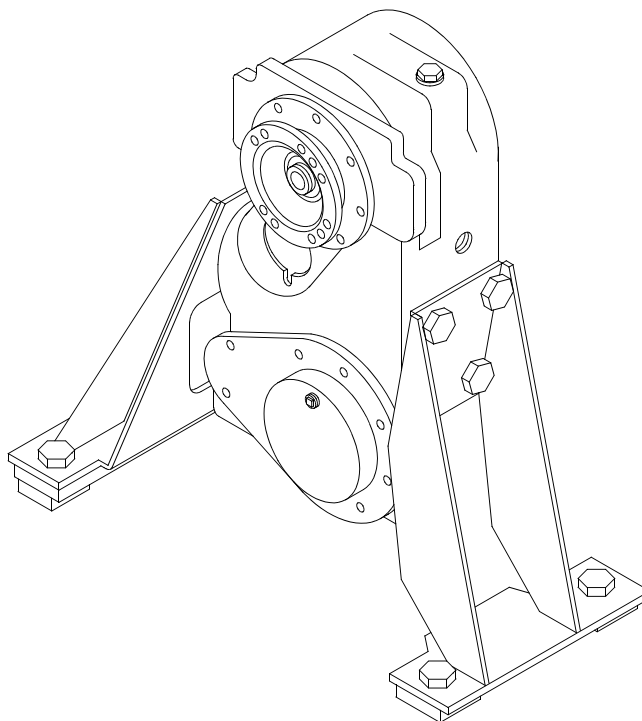

This manual supersedes TM 55-1945-205-24-4 dated 29 August 1997, including all changes.

DISTRIBUTION STATEMENT A - Approved for public release; distribution is unlimited.

HEADQUARTERS, DEPARTMENT OF THE ARMY

30 AUGUST 2003

WARNING SUMMARY

NO SMOKING

Smoking is prohibited aboard vessels.

JEWELRY

Remove rings, bracelets, wristwatches, and neck chains before working around or on a unit.

HEAVY OBJECTS

Handling heavily weighted objects can cause bodily injury. Do not lift materials or equipment over 50 lb without using appropriate material handling equipment.

BATTERIES

Do not smoke around batteries. Personnel must wear goggles and chemical resistant gloves when adding electrolyte and cleaning up spills.

HAZARD REPORTING

Report all hazards. It is your responsibility to report hazards through your chain-of-command.

HIGH VOLTAGE

Use extreme caution when checking energized circuits. Always place power off warning tags on power supply switches so that no one will apply power while performing maintenance.

HAZARDOUS FUMES IN CONFINED SPACES

The lazaret, engine, fuel and storage compartments are confined spaces and may contain hazardous fumes. Refer to FM 55-502 before entering a confined space. Never enter a confined space before checking the confined space with a gas free meter. Operate the exhaust plenum ventilation fan to remove fumes, especially following a fuel spill or CO2 discharge.

TORQUE VALUES

For torque not specified in an individual work package, refer to the Torque Limits Work Package located in the General Maintenance Section of this manual. Failure to tighten fasteners to specified torque may result in damage to equipment and death or injury to personnel.

NUCLEAR, BIOLOGICAL OR CHEMICAL

In the event equipment has been exposed to nuclear, biological or chemical warfare, the equipment shall be handled with extreme caution and decontaminated in accordance with FM 3-5, instructions for immediate, operational and thorough decon procedures adapted for the marine environment. Unprotected personnel can experience injury or death if residual toxic agents or radioactive material are present. If equipment is exposed to radioactive, biological or chemical agents, personnel must wear protective mask, hood, protective overgarments, chemical gloves and chemical boots in accordance with MOPP - level prescribed by the OIC or NCOIC.

FUELS

Personnel must wear chemical resistant gloves when handling fuels. Promptly wash exposed skin and change fuel-soaked clothing.

COOLANTS

Before opening coolant system, allow time to cool and wear effective hand, eye and skin protection.

NOISE

Hazardous noise levels may be present during the course of normal operations. All personnel shall wear appropriate single hearing protection at a minimum, especially during winch operations.

SAFETY WARNING ICONS



EAR PROTECTION

EAR PROTECTION - Headphones over ears shows that noise level will harm ears.



EYE PROTECTION

EYE PROTECTION - Person with goggles shows that the material will injure the eyes.



HEAVY OBJECTS

HEAVY OBJECTS - Human figure stooping over heavy object shows physical injury potential from improper lifting technique.



HEAVY PARTS

HEAVY PARTS - Foot with heavy object on top shows that heavy parts can crush and harm.



HEAVY PARTS

HEAVY PARTS 3 - Heavy object on human figure shows that heavy parts present a danger to life or limb.

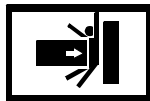

HEAVY PARTS

HEAVY PARTS 4 - Heavy object pushed up against human figure shows that heavy parts present a danger to life or limb.



HELMET PROTECTION

HELMET - Arrow bouncing off head with helmet shows that falling parts present a danger.

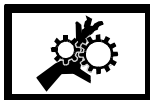

MOVING PARTS

MOVING PARTS 2 - Hand with fingers caught between gears shows that the moving parts of the equipment present a danger to life or limb.



SLICK FLOOR

SLICK FLOOR - Wavy line on floor with legs prone shows that slick floor presents a danger for falling.

HAZARDOUS MATERIAL WARNING ICONS

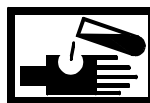

CHEMICAL

CHEMICALS - Drops of liquid on hand shows that the material will cause burns or irritation to human skin or tissue.

INSERT LATEST CHANGED PAGE/WORK PACKAGES. DESTROY SUPERSEDED DATA.

LIST OF EFFECTED PAGES / WORK PACKAGES

NOTE: The portion of text affected by the changes is indicated by a vertical line in the outer margins of the page. Changes to illustrations are indicated by a vertical line and/or miniature pointing hand adjacent to the changed area. When tables are updated or added, the change bar shall also be placed to the left of the table number and title.

Dates of issue for original and changed pages/work packages are:

Original 30 Aug 03
 Change 1 31 DEC 03

TOTAL NUMBER OF PAGES FOR FRONT AND REAR MATTER IS 26 AND TOTAL NUMBER OF WORK PACKAGES IS 30 CONSISTING OF THE FOLLOWING:

Page / WP No.	*Change No.	Page / WP No.	*Change No.
Front Cover (2 pgs)	1	WP 0024 00 (4 pgs)	0
Warning Summary (a-b pgs)	1	WP 0025 00 (6 pgs)	0
Change Sheet Transmittal (4 pgs)	1	Chp 4 title page	0
List of Effective Pages (A-B pgs)	1	WP 0026 00 (2 pgs)	1
Title Block Page (2 pgs)	1	WP 0027 00 (4 pgs)	1
Table of Contents (i-ii pgs)	1	WP 0028 00 (74 pgs)	1
How to Use This Manual (iii-iv pgs)	0	WP 0029 00 (2 pgs)	0
WP 0001 00 (4 pgs)	0	WP 0030 00 (2 pgs)	0
Chp 1 title page	0	INDEX -1 - INDEX - 2 (2 pgs)	0
WP 0002 00 (2 pgs)	0	DA Form 2028 (4 pgs)	0
WP 0003 00 (2 pgs)	0		
WP 0004 00 (2 pgs)	0	Authentication Page (2 pgs)	0
WP 0005 00 (2 pgs)	0	Back Cover (2 pgs)	1
Chp 2 title page	0		
WP 0006 00 (2 pgs)	0		
WP 0007 00 (2 pgs)	0		
WP 0008 00 (2 pgs)	0		
Chp 3 title page	0		
WP 0009 00 (2 pgs)	0		
WP 0010 00 (4 pgs)	0		
WP 0011 00 (2 pgs)	0		
WP 0012 00 (2 pgs)	1		
WP 0013 00 (4 pgs)	1		
WP 0014 00 (8 pgs)	0		
WP 0015 00 (24 pgs)	0		
WP 0016 00 (2 pgs)	1		
WP 0017 00 (6pgs)	1		
WP 0018 00 (4 pgs)	1		
WP 0019 00 (4 pgs)	1		
WP 0020 00 (4 pgs)	0		
WP 0021 00 (4 pgs)	0		
WP 0022 00 (2 pgs)	0		
WP 0023 00 (4 pgs)	0		

* Zero in this column indicates an original page.

TECHNICAL MANUAL

**UNIT, DIRECT SUPPORT AND GENERAL SUPPORT MAINTENANCE MANUAL
FOR
MODULAR CAUSEWAY SYSTEM (MCS)
WARPING TUG (WT)
TRANSFER CASE
738AN4NL4F
NSN 2040-01-505-2036**

DISTRIBUTION STATEMENT A - Approved for public release; distribution is unlimited.

TM 55-1945-205-24-3-4, 30 August 2003, is updated as follows:

1. File this sheet in front of the manual for reference.
2. The portion of text affected by the changes is indicated by a vertical line in the outer margins of the page.
3. Changes to illustrations are indicated by a vertical line and/or miniature pointing hand adjacent to the changed area.
4. When tables are updated or added, the change bar shall also be placed to the left of the table number and title.
5. Remove old pages and insert new pages as indicated below:

Remove Pages

a and b
A and B blank
Title Block Page
i and ii blank
Back Cover
Front Cover

Insert Pages

a and b
A and B blank
Title Block Page
i and iv blank
Back Cover
Front Cover

6. Replace the following work packages with their revised version:

Work Package Number

WP 0012 00
WP 0013 00
WP 0016 00
WP 0017 00
WP 0018 00
WP 0019 00
WP 0026 00
WP 0027 00
WP 0028 00

7. Add the following new work packages:

Work Package Number
None Applicable

By Order of the Secretary of the Army:

PETER J. SCHOOMAKER
General, United States Army
Chief of Staff

Official:

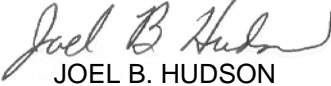
JOEL B. HUDSON
Administrative Assistant to the
Secretary of the Army
0330310

To be distributed in accordance with the initial distribution number (IDN) 256759 requirements for
TM 55-1945-205-24-3-4.

TECHNICAL MANUAL

**UNIT, DIRECT SUPPORT AND GENERAL SUPPORT
MAINTENANCE MANUAL
FOR**

**MODULAR CAUSEWAY SYSTEM (MCS)
WARPING TUG (WT) TRANSFER CASE
738AN4NL4F
NSN 2040-01-505-2036**

This manual supersedes TM 55-1945-205-24-4 dated 29 August 1997, including all changes.

REPORTING ERRORS AND RECOMMENDING IMPROVEMENTS

You can help improve this publication. If you find any mistakes or if you know of a way to improve the procedures, please let us know. Submit your DA Form 2028 (Recommended Changes to Equipment Technical Publications), through the Internet, on the Army Electronic Product Support (AEPS) website. The Internet address is <http://aeps.ria.army.mil>. If you need a password, scroll down and click on "ACCESS REQUEST FORM". The DA Form 2028 is located in the ONLINE FORMS PROCESSING section of the AEPS. Fill out the form and click on SUBMIT. Using this form on the AEPS will enable us to respond quicker to your comments and better manage the DA Form 2028 program. You may also mail, fax or email your letter or DA Form 2028 direct to: AMSTA-LC-CI / TECH PUBS, TACOM-RI, 1 Rock Island Arsenal, Rock Island, IL 61299-7630. The email address is TACOM-TECH-PUBS@ria.army.mil. The fax number is DSN 793-0726 or Commercial (309) 782-0726.

TABLE OF CONTENTS

WP Sequence No.

WARNING SUMMARY

HOW TO USE THIS MANUAL

General Information0001 00

CHAPTER 1 - DESCRIPTION AND THEORY OF OPERATION

Description and Data, Equipment Characteristics, Capabilities and Features0002 00
Description and Data, Location and Description of Major Components0003 00
Description and Data, Equipment Data0004 00
Theory of Operation0005 00

CHAPTER 2 - TROUBLESHOOTING PROCEDURES

Troubleshooting Procedures Index0006 00
Oil Level Increases In the Sump0007 00
Oil Level Decreases In the Sump0008 00

DISTRIBUTION STATEMENT A - Approved for public release; distribution is unlimited.

TABLE OF CONTENTS (CONT'D)

WP Sequence No.

CHAPTER 3 - MAINTENANCE INSTRUCTIONS

Service Upon Receipt0009 00
 Preventive Maintenance Checks and Services (PMCS), Introduction0010 00
 Preventive Maintenance Checks and Services and Lubrication Procedures0011 00
 Cleaning0012 00
 Servicing0013 00
 Removal and Installation0014 00
 Rebuild0015 00
 Breather, Replacement0016 00
 Lube Pump, Replacement0017 00
 Oil Cooler Lines, Replacement0018 00
 Oil Cooler, Replacement0019 00
 Upper Input Oil Seal, Replacement0020 00
 Upper Output Oil Seal, Replacement0021 00
 Lower Input Oil Seal, Replacement0022 00
 Bearing Cap Cover Gasket, Replacement0023 00
 Preparation for Storage or Shipment0024 00
 Torque Limits Work Package0025 00

CHAPTER 4 - SUPPORTING INFORMATION

References0026 00
 Maintenance Allocation Chart (MAC), Introduction0027 00
 Maintenance Allocation Chart (MAC)0028 00
 Expendable and Durable Items List (EDIL)0029 00
 Tool Identification List (TIL)0030 00

INDEX

AlphabeticalINDEX-1

HOW TO USE THIS MANUAL

This manual contains certain features to improve the convenience of using this manual and increase the user's efficiency. These features include:

a. Accessing Information

Information is accessed by referring to the Table of Contents, located in the front of this manual, or by looking in the Alphabetical Index, located in the back of this manual.

b. Illustrations

Various methods are used to locate and repair components. Locator illustrations in Controls and Indicator tables, PMCS tables, exploded views and cut-away diagrams make the information in the manual easier to understand and follow.

c. Using This Manual

When using this manual, read and understand the entire maintenance action before performing the task. Also, read and understand all warnings, cautions and notes as well as general safety precautions that apply to the task to be performed. The warning summary will inform personnel of hazards associated with the equipment to be worked on. However, the summary is not all inclusive and personnel should be aware at all times of hazardous conditions that may arise.

Prior to starting the procedures in this manual, the initial setup requirements are located directly above each procedure. The information is given to ensure all materials, expendables, tools and any other equipment necessary are readily available for use. The initial setup will be accomplished prior to starting the actual steps of each maintenance procedure.

Locating Major Components

Obtain the manual for the system to be worked on. Open to the Table of Contents located in the front of this manual. Find Chapter 1, *Description and Theory of Operation*. Under the chapter title you will find the work package titled *Location and Description of Major Components*. Turn to the work package indicated. This work package will give a brief description of the major components, and show an illustration of what the component looks like and its location.

The Alphabetical Index, located in the back of this manual, contains an alphabetical list of all sections of this manual. *Location and Description of Major Components* is found in section L. The work package is found on the right side of the title where the *Location and Description of Major Components* is located. Turn to the work package indicated to find the description and location of each component.

Troubleshooting Procedures

The Table of Contents or Alphabetical Index may be used to locate sections within this manual. To locate a particular troubleshooting procedure, open the manual to the Table of Contents located in the front of this manual. Find Chapter 2, *Troubleshooting Procedures*. Under this section, find a work package titled *Troubleshooting Index*. Turn to the work package indicated, which lists all of the troubleshooting procedures. Look down the list until you find the appropriate work package for the problem you are trying to solve. To the right side of the procedure will be a work package number. Turn to the work package indicated and follow the steps to complete the troubleshooting procedure. The procedures list the malfunction, symptom and the corrective action. The corrective action will indicate which maintenance procedure to go to for the repair of the symptom or what level of maintenance is capable of repair of the problem. Follow the procedures indicated to complete the task. At the top of the task you will have a section called INITIAL SETUP. There are five basic headings listed under INITIAL SETUP.

Test Equipment: Lists all test equipment (standard or special) required to troubleshoot, test and inspect the equipment covered in this manual. The test equipment is identified with an item number and work package number from the *Tool Identification List* located in Chapter 4, *Supporting Information*.

Tools: Lists all tools (standard or special) required to perform the task. Tools are identified with an item number and work package number from the *Tool Identification List* located in Chapter 4, *Supporting Information*.

Personnel Required: Lists all personnel necessary to perform the task.

Equipment Condition: Notes the conditions that must exist before starting the task. The equipment condition will also include any prerequisite maintenance tasks to be performed with reference to the work package number or to the TM number.

References: Includes any other manuals necessary to complete the task. When there are no references listed, all steps necessary to complete the task are contained within this manual. A listing of reference materials is contained in the work package *References* in Chapter 4, *Supporting Information*.

Maintenance Instructions

To locate a maintenance procedure, open the manual to the Table of Contents located in the front of this manual. Find Chapter 3, *Maintenance Instructions*. Look down the list and find the maintenance procedure to be accomplished. On the right side of the maintenance procedure will be a work package number. Turn to the work package indicated. Before beginning the maintenance task, look through the procedure to familiarize yourself with the entire maintenance procedure. At the top of the task you will have a section called INITIAL SETUP. There are five basic headings listed under INITIAL SETUP.

Tools: Lists all tools (standard or special) required to perform the task. Tools are identified with an item number and work package number from the *Tool Identification List* located in Chapter 4, *Supporting Information*.

Materials/Parts: Lists all parts or materials necessary to perform the task. Expendable and durables are identified with an item number from the applicable work package located in Chapter 4, *Supporting Information*.

Personnel Required: Lists all personnel necessary to perform the task.

References: Includes any other manuals necessary to complete the task. When there are no references listed, all steps necessary to complete the task are contained within this manual. A listing of reference materials is contained in the work package *References* in Chapter 4, *Supporting Information*.

Equipment Condition: Notes the conditions that must exist before starting the task. The equipment condition will also include any prerequisite maintenance tasks to be performed with reference to the work package number or to the TM number.

Test Equipment: Lists all test equipment (standard or special) required to troubleshoot, test and inspect the equipment covered in this manual. The test equipment is identified with an item number and work package number from the *Tool Identification List* located in Chapter 4, *Supporting Information*.

Repair Parts and Special Tools List

Refer to TM 55-1945-205-24P-3 when requisitioning parts, special tools and equipment.

Identify the mandatory repair parts required to perform this task listed at the top of the work package in the INITIAL SET-UP. Using the part number provided, refer to the part number index work package in TM 55-1945-205-24P-3. Look up the part number in the part number column and identify the figure and item number where the part is located. Turn to the figure and locate the item number listed. Verify that the item is correct.

**UNIT, DIRECT SUPPORT AND GENERAL SUPPORT MAINTENANCE
WARPING TUG
TRANSFER CASE
GENERAL INFORMATION**

SCOPE

This manual contains descriptions and maintenance instructions for Unit, Direct Support and General Support Maintenance levels for the warping tug transfer case, model number 738AN4NL4F.

Type of Manual: Unit, Direct Support and General Support maintenance.

Purpose of Equipment: Transfer power from the engine to the pump-jet.

MAINTENANCE FORMS, RECORDS AND REPORTS

Department of the Army forms and procedures used for equipment maintenance will be those prescribed by DA PAM 738-750, Functional Users Manual for The Army Maintenance Management System (TAMMS); and AR 700-138, Army Logistics Readiness and Sustainability.

REPORTING EQUIPMENT IMPROVEMENT RECOMMENDATIONS (EIR)

If any component in your system needs improvement, let us know. Send us an EIR. You, the user, are the only one who can tell us what you don't like about your equipment. Let us know why you don't like the design or performance. Put it on an SF 368, Product Quality Deficiency Report. Mail it to the address specified in DA PAM 738-750, or as specified by the contracting activity. We will send you a reply.

CORROSION PREVENTION AND CONTROL (CPC)

CPC of Army materiel is a continuing concern. It is important that any corrosion problems with this item be reported so that the problem can be corrected and improvements can be made to prevent the problem in future items.

While corrosion is typically associated with rusting of metals, it can also include deterioration of other materials, such as rubber and plastic. Unusual cracking, softening, swelling or breaking of the materials may be a corrosion problem. If a corrosion problem is identified, it can be reported using an SF 368, Product Quality Deficiency Report. Use of key words, such as "corrosion", "rust", "deterioration" or "cracking", will ensure that the information is identified as a CPC problem. The form should be submitted to the address specified in DA PAM 738-750, Functional Users Manual for The Army Maintenance Management System (TAMMS).

OZONE DEPLETING SUBSTANCES (ODS)

The continued use of ODS has been prohibited by Executive Order 12856 of 3 August 1993.

DESTRUCTION OF ARMY MATERIEL TO PREVENT ENEMY USE

The procedures for destruction of Army materiel to prevent enemy use are contained in TM 750-244-6.

PREPARATION FOR STORAGE AND SHIPMENT REFERENCE

Reference WP 0024 00 for preparation of storage or shipment of transfer case model number 738AN4NL4F.

LIST OF ABBREVIATIONS/ACRONYMS

Abbreviation/Acronym	Name
AEPS	Army Electronic Product Support
AOAP	Army Oil Analysis Program
AR	Army Regulation
ATQG	Army Tactical Quiet Generator
BX	Box
CAGEC	Commercial and Government Entity Code
CF	Causeway Ferry
cm	Centimeters
CPC	Corrosion Prevention Control
DA	Department of the Army
DA PAM	Department of the Army Pamphlet
Deg	Degrees
Dia.	Diameter
ea	Each
EDIL	Expendable and Durable Items List
EIR	Equipment Improvement Recommendations
F	Fahrenheit
FC	Floating Causeway
FGC	Functional Group Code
fl	Fluid
ft	Feet
ft lbs	Foot Pounds
GAL	Gallon
H	Hours (Operated)
HD	Hundred
HP	Horse Power
hrs.	Hours
in. lbs	Inch Pounds
in.	Inches
lb	Pounds
lg	long
kg	Kilograms
KW	Kilowatt
m	Meters
M	Monthly
MAC	Maintenance Allocation Chart
MCS	Modular Causeway System
mm	Millimeters
MTO&E	Modified Table of Organization and Equipment
NHA	Next Higher Assembly
N-m	Newton Meters
NO.	Number
NSN	National Stock Number
ODS	Ozone Depleting Substance
oz	Ounces
PLGR	Precision Lightweight GPS Receiver
PMCS	Preventive Maintenance Checks and Services
PN	Part Number
PSI	Pounds Per Square Inch

LIST OF ABBREVIATIONS/ACRONYMS (CONT'D)

Abbreviation/Acronym	Name
qt	Quart
RHIB	Rigid Hull Inflatable Boat
RPSTL	Repair Parts and Special Tools List
RPM	Revolutions Per Minute
RRDF	Roll-On/Roll-Off Discharge Facility
SAE	Society of Automotive Engineers
SF	Standard Form
SINGARS	Single Channel Ground and Airborne Radio
SMR	Source Maintenance Recoverability (code)
SRA	Specialized Repair Activity
TACOM	US Army Tank and Automotive Command
TAMMS	The Army Maintenance Management System
TIL	Tool Identification List
TM	Technical Manual
TMDE	Test Measuring Diagnostic Equipment
U/M	Unit of Measure
UUT	Unit Under Test
WP	Work Package
WT	Warping Tug

CHAPTER 1

DESCRIPTION AND THEORY OF OPERATION

FOR

MODULAR CAUSEWAY SYSTEM (MCS)

WARPING TUG (WT) TRANSFER CASE

UNIT, DIRECT SUPPORT AND GENERAL SUPPORT MAINTENANCE
WARPING TUG
TRANSFER CASE
DESCRIPTION AND DATA

EQUIPMENT CHARACTERISTICS, CAPABILITIES AND FEATURES

The transfer case is an integral part of the drive train of the warping tug. The transfer case compensates for the offset alignment between the lower position of the output shaft from the marine gear and the higher position of the input shaft of the pump-jet. Its gear ratio is 1:1 and, consequently, rotates at the same maximum speed of 2100 RPM as the engine and pump-jet.

The transfer case has its own oil cooler powered by a gear driven pump that is operated by rotation of the transfer case gearing. Lubricating oil circulates from the transfer case through external lines to a heat exchanger which cools the oil. Cooled oil is returned to the top of the transfer case, lubricating the upper gears and bearings and simultaneously cooling the entire transfer case.

There are two transfer cases per powered section: one for the starboard engine/drive train and one for the port engine/drive train.

UNIT, DIRECT SUPPORT AND GENERAL SUPPORT MAINTENANCE
WARPING TUG
TRANSFER CASE
DESCRIPTION AND DATA

LOCATION AND DESCRIPTION OF MAJOR COMPONENTS

TRANSFER CASE

Location

The transfer case is located between the marine gear and the input flange of the pump-jet and is connected to both with drive shafts. There are two transfer cases: one for the starboard engine and one for the port engine.

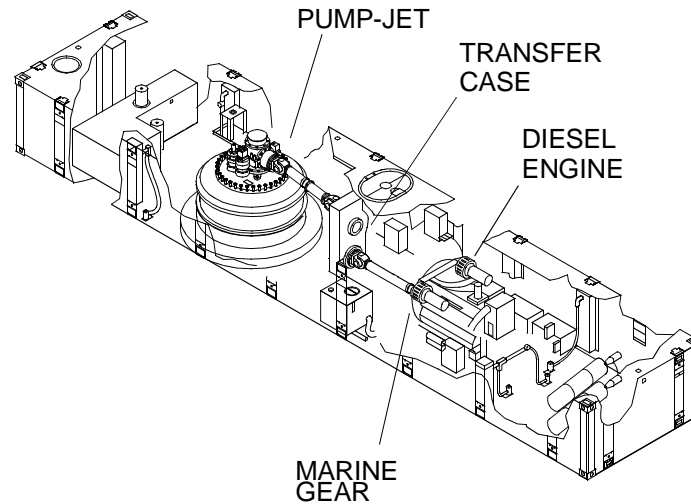

Description

The transfer case compensates for offset alignment between the output flange of the marine gear and the input flange of the pump-jet. It has a 1:1 gear ratio. It utilizes spur gears throughout and is equipped with an oil pump that circulates lubricating oil from its gearcase, through an oil cooler connected to the engine raw water cooling system and back to the top of the transfer case to lubricate the upper gears. Weight of the transfer case is approximately 450 lb dry.

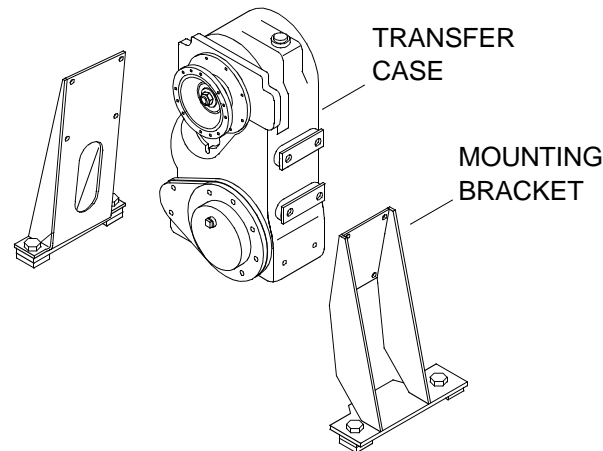

**UNIT, DIRECT SUPPORT AND GENERAL SUPPORT MAINTENANCE
WARPING TUG
TRANSFER CASE
DESCRIPTION AND DATA**

EQUIPMENT DATA

The following table provides data applicable to major component levels.

Table 1. CF Equipment Data.

ITEM CHARACTERISTIC	DESCRIPTION
TRANSFER CASE (2 PER CF)	
Weight, Dry	450 lb (204.11 kg)
Oil Capacity	11 Pints (5.2 liter)
Ratio	1:1
Torque Rating, Continuous Duty	3725 ft lbs (5051.1 N-m)
Maximum Operating Speed	5000 RPM

UNIT, DIRECT SUPPORT AND GENERAL SUPPORT MAINTENANCE
WARPING TUG
TRANSFER CASE
THEORY OF OPERATION

SYSTEM THEORY

The transfer case is used to compensate for the offset alignment between the output flange of the marine gear and the input flange of the pump-jet. It has a 1:1 gear ratio and utilizes spur gears throughout. The transfer case is equipped with an oil pump that circulates lubrication oil from its gearcase through an oil cooler, plumbed off of the engine raw water cooling system, then back to the top to the transfer case to lubricate the upper gearing. The transfer case is connected to the marine gear and the pump-jet via drive shafts.

CHAPTER 2

**UNIT, DIRECT SUPPORT AND GENERAL SUPPORT
TROUBLESHOOTING PROCEDURES
FOR
MODULAR CAUSEWAY SYSTEM (MCS)
WARPING TUG (WT) TRANSFER CASE**

**UNIT, DIRECT SUPPORT AND GENERAL SUPPORT MAINTENANCE
WARPING TUG
TRANSFER CASE
TROUBLESHOOTING PROCEDURES INDEX**

MALFUNCTION/SYMP TOM**TROUBLESHOOTING PROCEDURE**

Oil Level Increases In The Sump

WP 0007 00

Oil Level Decreases In The Sump

WP 0008 00

**UNIT, DIRECT SUPPORT AND GENERAL SUPPORT MAINTENANCE
WARPING TUG
TRANSFER CASE
TROUBLESHOOTING PROCEDURES**

INITIAL SETUP:**Personnel Required**

Engineer 88L

ReferencesTM 55-1945-205-10-3

TROUBLESHOOTING PROCEDURE

OIL LEVEL INCREASES IN THE SUMP

SYMPTOM

Oil level increases.

MALFUNCTION

Oil cooler cooling tubes leaking, causing raw water to enter transfer case.

CORRECTIVE ACTION

Replace oil cooler. (WP 0019 00)

Service transfer case. (WP 0013 00)

Perform operational check of drive train. (TM 55-1945-205-10-3)

END OF WORK PACKAGE

**UNIT, DIRECT SUPPORT AND GENERAL SUPPORT MAINTENANCE
WARPING TUG
TRANSFER CASE
TROUBLESHOOTING PROCEDURES**

INITIAL SETUP:**Personnel Required**

Engineer 88L

References

TM 55-1945-205-10-3

TROUBLESHOOTING PROCEDURE

OIL LEVEL DECREASES IN THE SUMP

SYMPTOM

Oil level decreases.

MALFUNCTION

Oil cooler cooling tubes leaking, causing transfer case oil to escape with the raw water.

CORRECTIVE ACTION

Replace oil cooler. (WP 0019 00)

Perform operational check of drive train. (TM 55-1945-205-10-3)

MALFUNCTION

Transfer case lines, hoses or fittings leaking.

CORRECTIVE ACTION

Replace leaking lines, hoses and fittings. (WP 0018 00)

Perform operational check of drive train. (TM 55-1945-205-10-3)

MALFUNCTION

Rotating shaft seals are leaking.

CORRECTIVE ACTION

Replace rotating seals. (WP 0020 00, WP 0021 00 and WP 0022 00)

Perform operational check of drive train. (TM 55-1945-205-10-3)

MALFUNCTION

Gaskets are leaking.

CORRECTIVE ACTION

Replace gaskets. (WP 0023 00)

Perform operational check of drive train. (TM 55-1945-205-10-3)

END OF WORK PACKAGE

CHAPTER 3

**UNIT, DIRECT SUPPORT AND GENERAL SUPPORT
MAINTENANCE INSTRUCTIONS
FOR
MODULAR CAUSEWAY SYSTEM (MCS)
WARPING TUG (WT) TRANSFER CASE**

**DIRECT SUPPORT MAINTENANCE
WARPING TUG
TRANSFER CASE
SERVICE UPON RECEIPT**

INITIAL SETUP:**Tools**

- Tool Kit, General Mechanic's (Item 13, WP 0030 00)
- Pan, Drain (Item 9, WP 0030 00)
- Goggles, Industrial (Item 7, WP 0030 00)
- Gloves, Chemical (Item 5, WP 0030 00)
- Apron, Utility (Item 1, WP 0030 00)
- Sling, Engine and Transmission, Motor Vehicle (Item 12, WP 0030 00)

Materials/Parts

- Spill Clean-Up Kit, Hazardous Material (Item 6, WP 0029 00)

Personnel Required

- Engineer 88L
-

SERVICE UPON RECEIPT

WARNING

**HEAVY OBJECTS**

1. Using engine and transmission sling, remove transfer case (1) from shipping container.

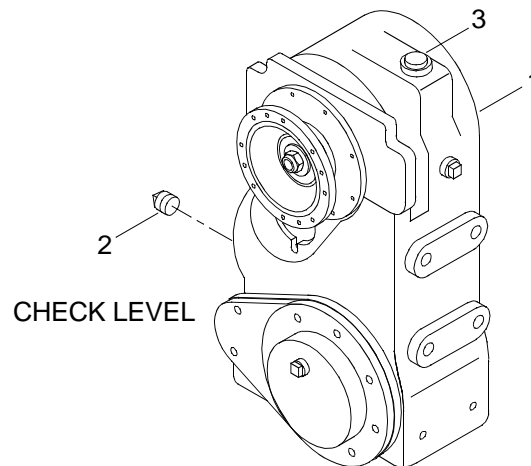

2. Inspect transfer case for damage that might have occurred during shipment. Report any damage to your supervisor.
3. Check the equipment against the packing slip to see if shipment is complete. Report all discrepancies to your supervisor.

-
4. Drain transfer case lubricating oil to correct operating level using check level (2) opening.
- a. Place a drain pan under check level plug (2) and loosen breather (3).

WARNING



CHEMICAL



EYE PROTECTION

- b. Remove check level plug (2) and allow oil to drain down to check level opening.
- c. Install check level plug (2).
- d. Tighten breather (3).

WARNING



CHEMICAL



EYE PROTECTION

5. Remove drain pan and dispose of contents in accordance with local procedures.

WARNING



CHEMICAL

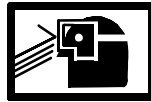

EYE PROTECTION



SLICK FLOOR

6. Clean up spilled fluid with a spill kit and dispose of spill kit waste in accordance with local procedures.

END OF WORK PACKAGE

**UNIT LEVEL MAINTENANCE
WARPING TUG
TRANSFER CASE
PREVENTIVE MAINTENANCE CHECKS AND SERVICES (PMCS)
INTRODUCTION**

INTRODUCTION

General

Preventive Maintenance Checks and Services (PMCS) are performed to keep the warping tug transfer case in operating condition. The checks are used to find, correct or report problems.

Do "Hourly PMCS" at the designated hours. If equipment has not been operated for the prescribed hours do the "Monthly PMCS".

Do "Monthly PMCS" once a month.

If you find something wrong when performing PMCS, fix it, if you can, using troubleshooting procedures and/or maintenance procedures.

The right-hand column of the PMCS table lists conditions that make the equipment not fully mission capable. Write up items not fixed on DA Form 2404 for your support maintenance personnel. For further information on how to use this form, see DA PAM 738-750.

Leakage Definition

CAUTION

Equipment operation is allowable with minor leakages (Class I or II) except for fuel leaks. Of course, consideration must be given to the fluid capacity of the item or system being checked. When in doubt, ask your supervisor. Failure to comply could result in damage to equipment.

NOTE

When operating with Class I or II leaks, continue to check fluid levels as required in your PMCS. Class III leaks should be reported immediately to your supervisor.

Leakage definitions for Unit, Direct Support and General Support PMCS.

It is necessary to know how fluid leakage affects the status of the equipment. The following are definitions of the classes of leakage an operator or crew member needs to know to be able to determine the condition of the leak. Learn and then be familiar with them, and REMEMBER - WHEN IN DOUBT, ASK YOUR SUPERVISOR.

CLASS I - Seepage of fluid (as indicated by wetness or discoloration) not great enough to form drops.

CLASS II - Leakage of fluid great enough to form drops, but not enough to cause drops to drip from item being checked.

CLASS III - Leakage of fluid great enough to form drops that fall from the item being checked.

Inspection

Look for signs of a problem or trouble. Senses help. You can feel, smell, hear or see many problems. Be alert when operating the equipment.

Inspect to see if items are in good condition. Are they correctly assembled, stowed, secured, excessively worn, leaking, corroded or properly lubricated? Correct any problems found or notify your supervisor.

There are some common items to check all over the equipment. These include the following.

1. Bolts, clamps, nuts and screws: Continuously check for looseness. Look for chipped paint, bare metal, rust or corrosion around bolt and screw heads and nuts. Tighten them when you find them loose.
2. Welds: Many items on the equipment are welded. To check these welds, look for chipped paint, rust, corrosion or gaps.
3. Electrical wires, connectors and harnesses: Tighten loose connectors. Look for cracked or broken insulation, bare wires and broken connectors.
4. Hoses and fluid lines: Look for wear, damage and leaks and make sure clamps and fittings are tight. Wet spots mean a leak. A stain by a fitting or connector can also mean a leak.

Lubrication Service Intervals - Normal Conditions

For safer, more trouble free operations, make sure that your equipment is serviced when it needs it. For the proper lubrication and service intervals, see the PMCS table.

Lubrication Service Intervals - Unusual Conditions

Your equipment will require extra service and care when you operate under unusual conditions. High or low temperatures, long periods of hard use or continued use in blowing sand, dust or in a salty spray type of environment will break down lubricants, requiring the addition or changing of lubricants more often.

Lubrication Symbols

There are no lubrication symbols used in this manual.

Lubrication Intervals

The following lubrication intervals are used in the PMCS table.

H - hours operated

M - monthly

CLEANING AND LUBRICATION

CAUTION

Follow all cleaning and lubrication instructions carefully. Failure to do so can result in damage to equipment.

Keeping equipment cleaned and properly lubricated will help to avoid possible problems or premature equipment failure.

1. Thoroughly wash all equipment exposed to salt spray with clean, fresh water.
2. Lubricate all equipment at conclusion of the operation and prior to equipment storage.
3. Clean the exterior of the components with a clean, dry cloth or a soft bristled brush.

Army Oil Analysis Program (AOAP)

Engine oil/transmission oil/hydraulic fluids must be sampled at 90 days or 100 operating hours as prescribed by DA PAM 738-750, Functional Users Guide for the Army Maintenance Management System (TAMMS).

Corrosion Prevention and Control (CPC)

Corrosion Prevention and Control (CPC) of Army materiel is a continuing concern. It is important that any corrosion problems with this item be reported so that the problem can be corrected and improvements can be made to prevent the problem in future items.

Corrosion is typically associated with rusting of metals or galvanic corrosion, which produces a white powder. The category of corrosion also includes deterioration of other materials, such as rubber and plastic. Unusual cracking, softening, swelling or breaking of the materials may be a corrosion problem. If a corrosion problem is identified, it can be reported using an SF 368, Product Quality Deficiency Report. Use of key words, such as "corrosion", "rust", "deterioration" or "cracking", will ensure that the information is identified as a CPC problem. The form should be submitted to the address specified in DA PAM 738-750.

**UNIT LEVEL MAINTENANCE
WARPING TUG
TRANSFER CASE
PREVENTIVE MAINTENANCE CHECKS AND SERVICES (PMCS)
AND LUBRICATION PROCEDURES**

INITIAL SETUP:

Tools

Tool Kit, General Mechanic's (Rail and Marine) (Item 14, WP 0030 00)

Personnel Required

Engineer 88L

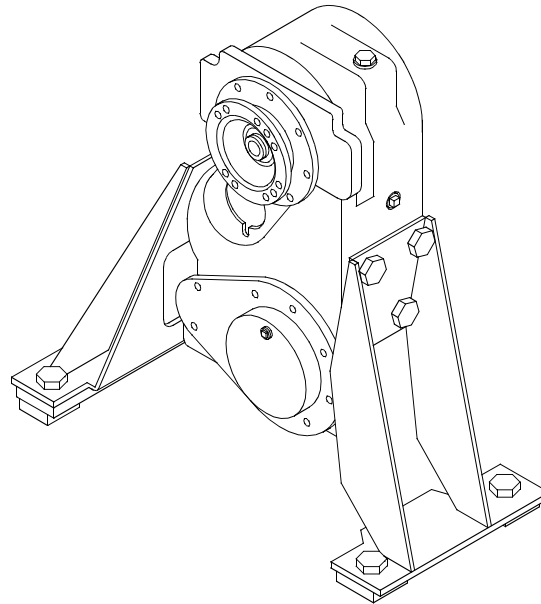

TRANSFER CASE

Table 1. Preventive Maintenance Checks and Services and Lubrication Procedures. (PMCS)

ITEM NO.	INTERVAL	MAN-HOURS	ITEM TO BE CHECKED OR SERVICED	PROCEDURE	EQUIPMENT NOT READY/ AVAILABLE IF:
1	24 Operating Hours	1.5	Transfer Case	Change oil after first 24 hours of operation. (WP 0013 00)	
1	Monthly	1.5	Transfer Case	Change oil monthly. (WP 0013 00)	

END OF WORK PACKAGE

**UNIT LEVEL MAINTENANCE
WARPING TUG
TRANSFER CASE
CLEANING**

INITIAL SETUP:**Tools**

Tool Kit, General Mechanic's (Rail and Marine) (Item 14, WP 0030 00)
Gloves, Chemical (Item 5, WP 0030 00)
Goggles, Industrial (Item 7, WP 0030 00)
Apron, Utility (Item 1, WP 0030 00)
Brush, Stencil (Soft Bristle) (Item 2, WP 0030 00)

Materials/Parts

Cleaner (Item 3, WP 0029 00)
Cloth, Cleaning (Item 4, WP 0029 00)

Personnel Required

Engineer 88L

Equipment Condition

Transfer Case Cool To Touch.
Propulsion Module Ventilated. (TM 55-1945-205-24-3-1)

CLEAN TRANSFER CASE**NOTE**

This task is typical for both port and starboard transfer cases.

1. Verify disconnect circuit breaker (1) on A10 panel is positioned to OFF.

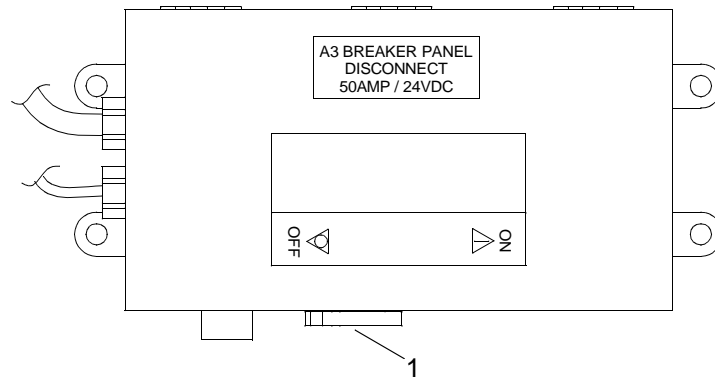

WARNING

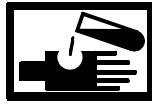
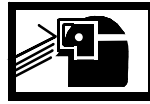
**CHEMICAL****EYE PROTECTION**

2. Apply cleaner to the exterior of the transfer case (2). Use a cleaning cloth.

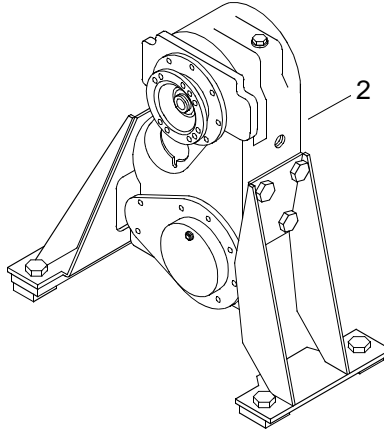

WARNING

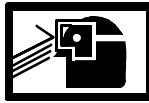
**EYE PROTECTION**

3. Use a soft bristle brush to remove hardened debris.
4. Rinse the exterior with clean water.
5. Use a cleaning cloth to wipe down the exterior of the transfer case (2).

WARNING

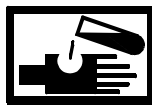
**CHEMICAL****EYE PROTECTION**

6. Dispose of cleaning cloths in accordance with local procedures.

END OF WORK PACKAGE

**UNIT LEVEL MAINTENANCE
WARPING TUG
TRANSFER CASE
SERVICING**

INITIAL SETUP:**Tools**

Tool Kit, General Mechanic's (Rail and Marine) (Item 14, WP 0030 00)
Pan, Drain (Item 9, WP 0030 00)
Goggles, Industrial (Item 7, WP 0030 00)
Gloves, Chemical (Item 5, WP 0030 00)
Apron, Utility (Item 1, WP 0030 00)

Materials/Parts

Lubricating Oil, Engine (Item 5, WP 0029 00)
Qty 6
Spill Clean-Up Kit, Hazardous Material (Item 6, WP 0029 00)

Personnel Required

Engineer 88L

Equipment Condition

Propulsion Module Ventilated. (TM 55-1945-205-24-3-1)

DRAIN TRANSFER CASE

1. Verify disconnect circuit breaker (1) on A10 panel is positioned to OFF.

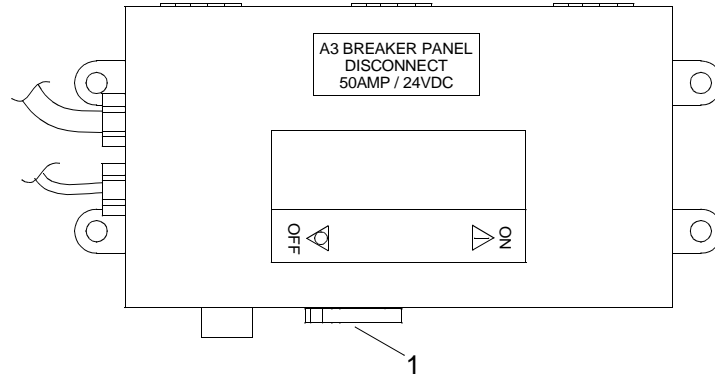

2. Place a drain pan under the drain plug (2).

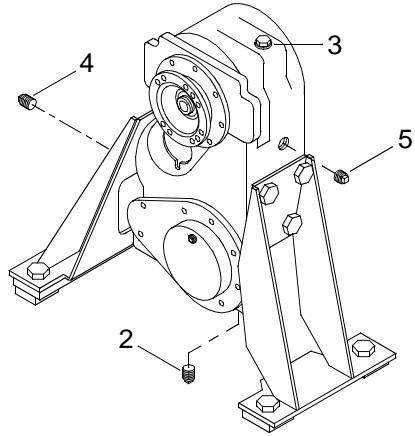

3. Loosen breather (3).

WARNING

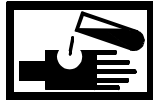

CHEMICAL

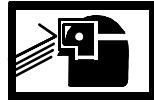

EYE PROTECTION

4. Remove drain plug (2) and drain oil into drain pan.

WARNING



CHEMICAL

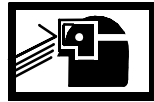

EYE PROTECTION

5. Install and tighten drain plug (2) after oil has drained.

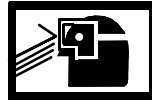
SERVICE TRANSFER CASE**WARNING****CHEMICAL****EYE PROTECTION**

1. Remove check plug (4).

WARNING**CHEMICAL****EYE PROTECTION**

2. Remove fill plug (5).

WARNING**CHEMICAL****EYE PROTECTION**

3. Service the transfer case with 11 pints (5.17 Liters) of engine lubricating oil through the fill plug (5).
4. Install the check plug (4) and tighten.
5. Install the fill plug (5) and tighten.
6. Tighten breather (3).

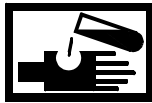
WARNING**CHEMICAL****EYE PROTECTION**

7. Remove drain pan and dispose of contents in accordance with local procedures.

WARNING**CHEMICAL****EYE PROTECTION****SLICK FLOOR**

8. Clean up any spilled oil with a spill kit and dispose of spill kit waste in accordance with local procedures.

END OF WORK PACKAGE

**DIRECT SUPPORT MAINTENANCE
WARPING TUG
TRANSFER CASE
REMOVAL AND INSTALLATION**

INITIAL SETUP:**Tools**

Tool Kit, General Mechanic's (Item 13, WP 0030 00)
Gloves, Chemical (Item 5, WP 0030 00)
Goggles, Industrial (Item 7, WP 0030 00)
Pan, Drain (Item 9, WP 0030 00)
Wrench, Torque (0-150 ft lbs) (Item 18, WP 0030 00)
Wrench, Pipe (Item 15, WP 0030 00)
Sling, Engine and Transmission, Motor Vehicle (Item 12, WP 0030 00)

Materials/Parts

Tape, Antiseize (Item 9, WP 0029 00)
Spill Clean-Up Kit, Hazardous Material (Item 6, WP 0029 00)
Lubricating Oil, Engine (Item 5, WP 0029 00)
Qty 6

Personnel Required

Engineer 88L

References

TM 55-1945-205-10-3

Equipment Condition

Propulsion Module Dry-Docked.
Main Mast Navigation Assembly Removed. (TM 55-1945-205-24-3-1)
SINGARS Radio Antenna Removed. (TM 11-5820-890-10-8)
Powered Section Operators Cab Removed. (TM 55-1945-205-24-3-1)
Powered Section Intake Plenum Assembly Removed. (TM 55-1945-205-24-3-1)
Powered Section Engine Hatch Removed. (TM 55-1945-205-24-3-1)
Drive Train Transfer Case To Pump-Jet Machinery Guards Removed. (TM 55-1945-205-24-3-1)
Drive Train Marine Gear To Transfer Case Machinery Guards Removed. (TM 55-1945-205-24-3-1)
Drive Train Drive Shafts Removed. (TM 55-1945-205-24-3-1)

REMOVE TRANSFER CASE

1. Drain oil from transfer case (1).

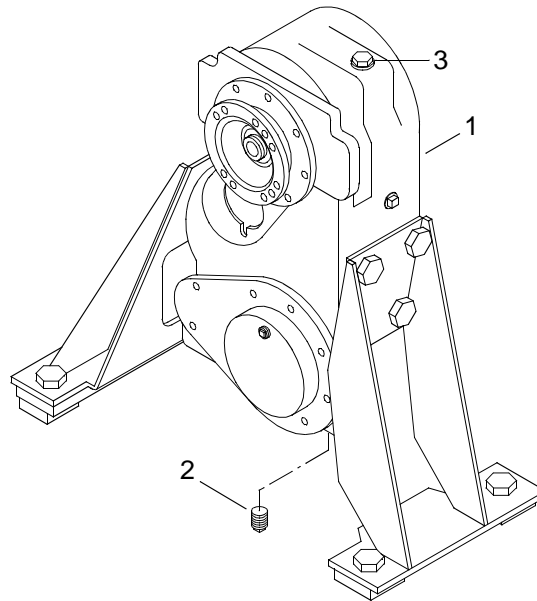

- a. Place a drain pan under the drain plug (2).
- b. Loosen breather (3).

WARNING



CHEMICAL

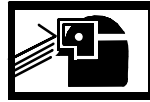

EYE PROTECTION

- c. Remove drain plug (2) and drain oil into pan.

WARNING

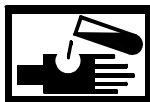

CHEMICAL



EYE PROTECTION

- d. Install drain plug (2) after oil has drained.
- e. Tighten drain plug (2).

WARNING



CHEMICAL



EYE PROTECTION

3. Disconnect oil inlet hose (4) from male connector (5).

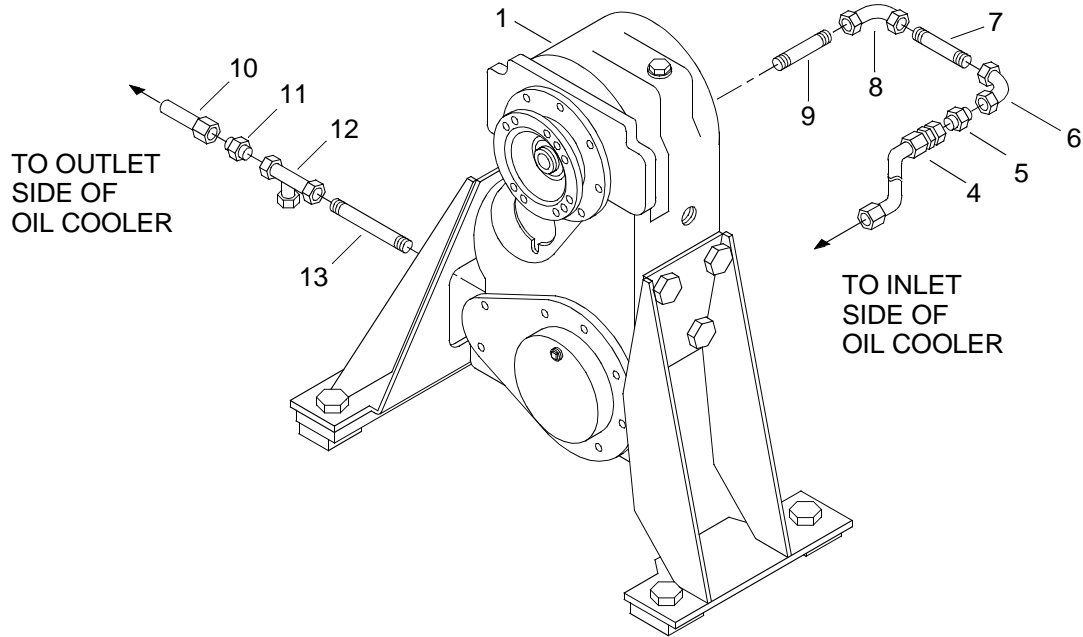

WARNING

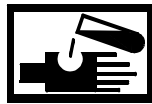

CHEMICAL

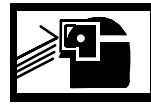

EYE PROTECTION

- Remove male connector (5), 90 degree elbow (6), pipe nipple (7) and 90 degree elbow (8) as an assembly from pipe nipple (9) as an assembly.

WARNING



CHEMICAL

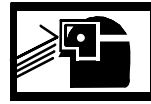

EYE PROTECTION

- Using a pipe wrench, remove pipe nipple (9).

WARNING

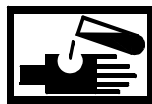

CHEMICAL



EYE PROTECTION

- Disconnect oil outlet hose (10) from male connector (11).

WARNING

**CHEMICAL****EYE PROTECTION**

7. Remove tee (12) and male connector (11) as an assembly from pipe nipple (13).

WARNING

**CHEMICAL****EYE PROTECTION**

8. Using a pipe wrench, remove pipe nipple (13).
9. Remove transfer case (1) from mount brackets (14).

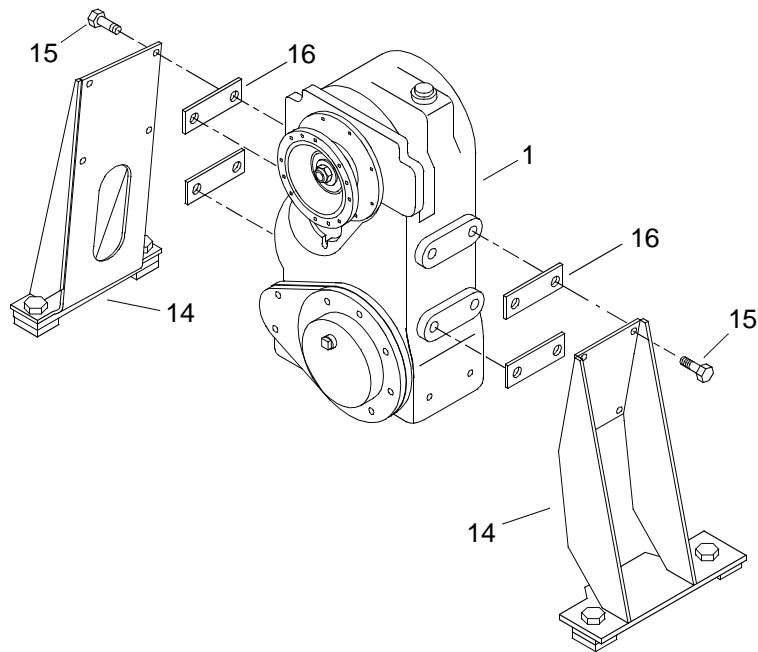

- a. Attach engine and transmission sling to transfer case (1) and take up tension.
- b. Remove eight hex head cap screws (15) that secure transfer case (1) to support brackets (14).

 WARNING



HEAVY OBJECTS



HEAVY PARTS

 CAUTION

When lifting transfer case out of transfer case support brackets, be careful not to bend or damage supports. Failure to comply may result in damage to equipment.

- c. Using the engine and transmission sling, carefully lift and maneuver the transfer case (1) out of supports (14) and collect spacers (16).

 WARNING



HEAVY PARTS

- d. Continue to lift transfer case (1) out of powered section via the intake plenum or operator cab access hole.
- e. Lower transfer case (1) to suitable work area.
- f. Once the transfer case (1) is lowered and tension is removed from the sling, remove sling from transfer case (1).

10. Prepare transfer case (1) for shipment. (WP 0024 00)

INSTALL TRANSFER CASE

1. Mount transfer case (1) to support brackets (14).
 - a. Attach engine and transmission sling to transfer case (1).

 WARNING



HEAVY OBJECTS



HEAVY PARTS

 CAUTION

When lowering transfer case into transfer case support brackets, be careful not to bend or damage supports. Failure to comply may result in damage to equipment.

- b. Using engine and transmission sling, carefully lower and maneuver the transfer case (1) into the hull of the powered module via the operators cab or intake plenum access hole.

WARNING

**HEAVY OBJECTS**

- c. Carefully align transfer case (1) between support brackets (14).
 - d. Install four spacers (16) and eight hex head cap screws (15) securing transfer case (1) to support brackets (14).
 - e. Using torque wrench, torque hex head cap screws (15) to 95 ft lbs (129 N-m).
 - f. Remove sling.
2. Wrap pipe nipple (13) with antiseize tape.
 3. Install pipe nipple (13).
 4. Using a pipe wrench, tighten pipe nipple (13).
 5. Install tee (12) and male connector (11) on pipe nipple assembly (13).
 6. Connect hose (10) with male connector (11).
 7. Wrap pipe nipple (9) with antiseize tape.
 8. Install pipe nipple (9).
 9. Using a pipe wrench, tighten pipe nipple (9).
 10. Install male connector (5), 90 degree elbow (6), pipe nipple (7) and 90 degree elbow (8) as an assembly onto pipe nipple (9).
 11. Install hose assembly (4) on male connector (5).
 12. Fill transfer case (1).

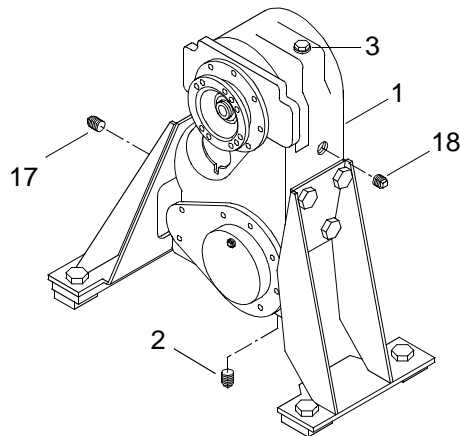

- a. Remove check plug (17).

- b. Remove fill plug (18).

WARNING



CHEMICAL



EYE PROTECTION

- c. Service the transfer case (1) with 11 pints (5.17 Liters) of lubricating oil through the fill plug (18).
- d. Install the check plug (17) and tighten.
- e. Install the fill plug (18) and tighten.
- f. Tighten breather (3).

WARNING



CHEMICAL

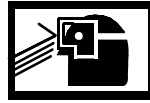

EYE PROTECTION

13. Remove drain pan and dispose of contents in accordance with local procedures.

WARNING



CHEMICAL



EYE PROTECTION



SLICK FLOOR

14. Clean up any spilled fluid with a spill kit and dispose of spill kit waste in accordance with local procedures.
15. Install drive train drive shafts. (TM 55-1945-205-24-3-1)
16. Install drive train marine gear to transfer case machinery guards. (TM 55-1945-205-24-3-1)
17. Install drive train transfer case to pump-jet machinery guards. (TM 55-1945-205-24-3-1)
18. Install powered section engine hatch. (TM 55-1945-205-24-3-1)
19. Install powered section intake plenum assembly. (TM 55-1945-205-24-3-1)
20. Install powered section operators cab. (TM 55-1945-205-24-3-1)
21. Install SINGARS radio antenna. (TM 11-5820-890-10-8)
22. Install main mast navigation assembly. (TM 55-1945-205-24-3-1)
23. Perform operational check of drive train. (TM 55-1945-205-10-3)

END OF WORK PACKAGE

**GENERAL SUPPORT MAINTENANCE
WARPING TUG
TRANSFER CASE
REBUILD**

INITIAL SETUP:**Tools**

Tool Kit, General Mechanic's (Item 13, WP 0030 00)
 Wrench, Torque (100-600 ft lbs) (Item 17, WP 0030 00)
 Wrench, Torque (0-150 ft lbs) (Item 18, WP 0030 00)
 Puller Kit, Universal (Item 11, WP 0030 00)
 Hammer, Hand (Item 8, WP 0030 00)
 Apron, Utility (Item 1, WP 0030 00)
 Gloves, Chemical (Item 5, WP 0030 00)
 Gloves, Men's and (Leather Palm) (Item 5, WP 0030 00)
 Goggles, Industrial (Item 7, WP 0030 00)
 Bushing Driver Set (Item 3, WP 0030 00)
 Press, Arbor, Hand Operated (Item 10, WP 0030 00)
 Crowbar (Item 4, WP 0030 00)

Materials/Parts

Gasket (97271) NSN 5330-01-283-5427 PN H738-223-3 Qty 2	Nut, Self Locking Hexagon (97271) NSN 5310-01-283-7529 PN 500898 Qty 3
Gasket (97271) PN H738-223-1	Washer, Flat (97271) PN H184-W Qty 3
Gasket (97271) PN H738-223-4 Qty 2	Cleaner (Item 3, WP 0029 00) Cloth, Cleaning (Item 4, WP 0029 00) Lubricating Oil, Engine (Item 5, WP 0029 00) Wedge, Wood (Item 10, WP 0029 00) Qty 2
Seal, Plain (97271) NSN 5330-01-283-4140 PN H60-463-7 Qty 3	

Personnel Required

Engineer 88L

DISASSEMBLE TRANSFER CASE

1. Remove upper shaft (1) from transfer case (2).

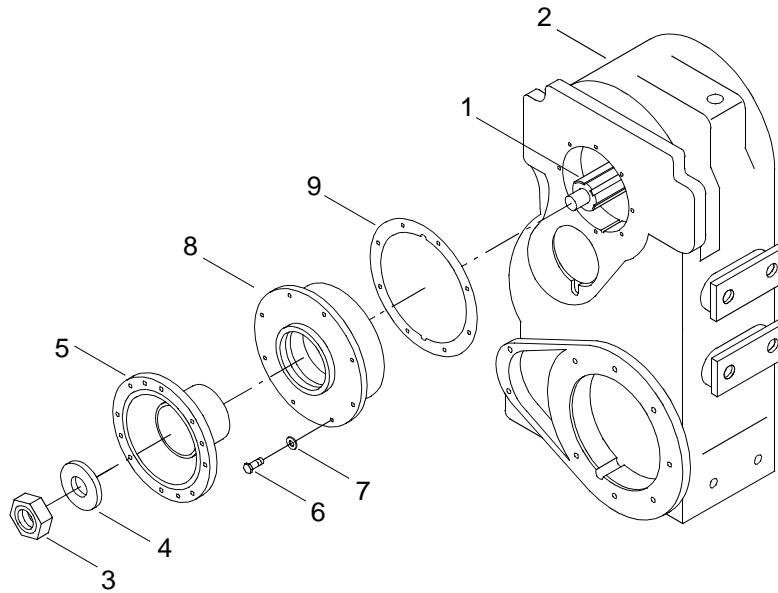

- a. Remove lock nut (3) and washer (4) from upper shaft (1).
- b. Remove flange (5) from upper shaft (1).
- c. Remove eight cap screws (6) and lock washers (7) from bearing cap (8).

WARNING



EYE PROTECTION

- d. Using a crowbar, carefully remove bearing cap (8).
- e. Remove gasket (9) and discard.
- f. Position bearing cap (8) on wooden wedges.

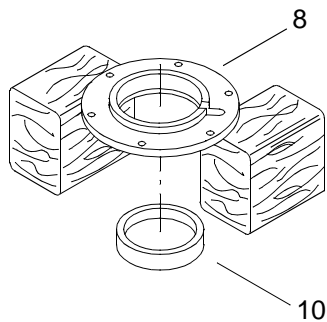

WARNING

**EYE PROTECTION**

- g. Using a brass drift and hammer, remove and discard seal (10) from bearing cap (8).
- h. Remove bearing (11) from cap (8).

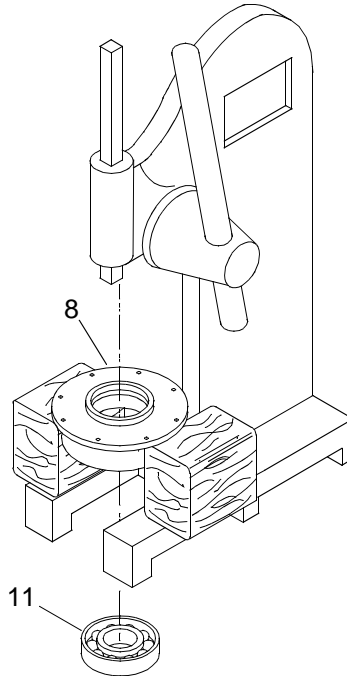

{1} Place wood wedges on arbor press.

WARNING

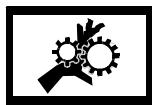
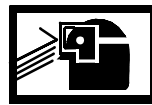
**MOVING PARTS****EYE PROTECTION**

{2} Press bearing (11) out of bearing cap (8).

- i. Remove lock nut (12) and washer (13) from upper shaft (1) and discard.

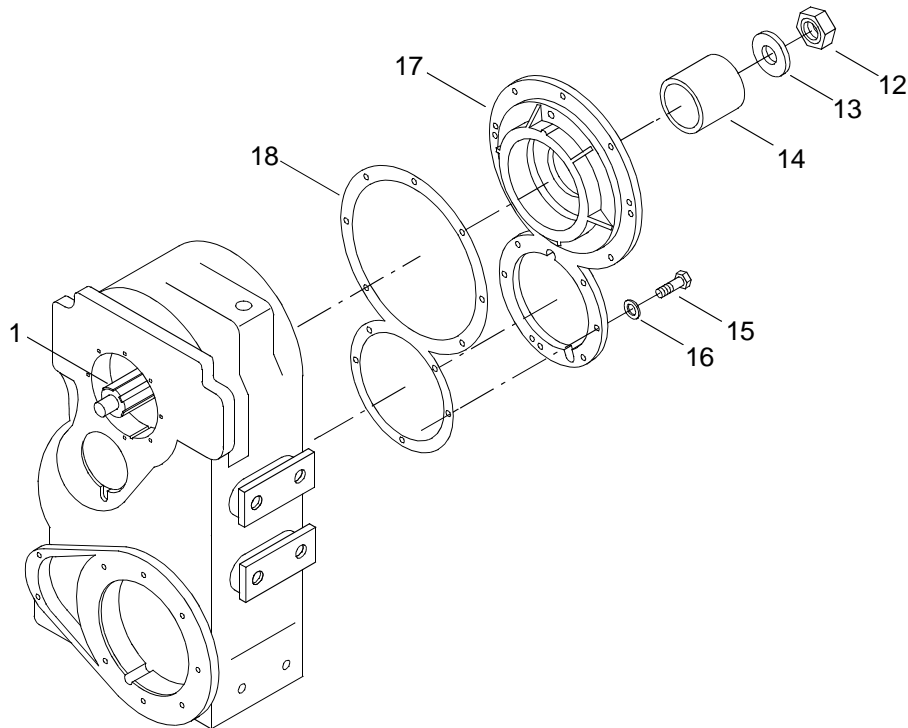

- j. Remove sleeve (14) from upper shaft (1).
- k. Remove 12 cap screws (15) and lock washers (16) from cover (17).
- l. Install three cap screws (15) in threaded holes provided in cover (17) until they reach the bottom of the threaded holes.
- m. Turn the three cap screws (15) consecutively 1/8 turn clockwise until cover (17) has been removed.
- n. Remove cap screws (15) from cover (17).
- o. Remove and discard gasket (18).
- p. Position cover (17) on wooden wedges.

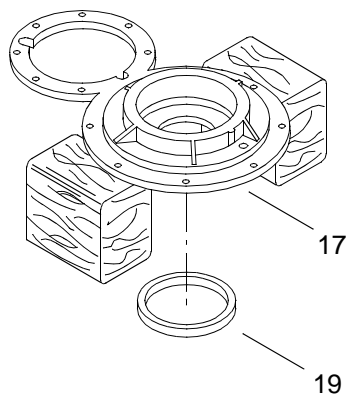

WARNING

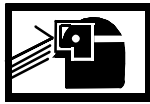
**EYE PROTECTION**

- q. Using a brass drift and a hammer, remove seal (19) from cover (17) and discard.
- r. Remove spacer (20) from shaft (1).

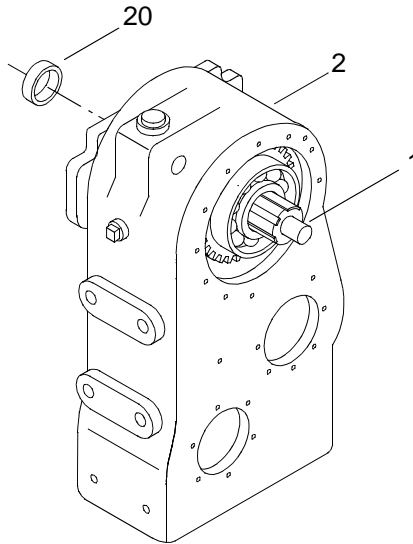

WARNING

**EYE PROTECTION****CAUTION**

When driving out shaft, care should be taken not to damage threads or allow shaft to fall to the floor. Failure to comply could result in damage to equipment.

- s. Using a hand hammer, drive upper shaft (1) out of transfer case (2).

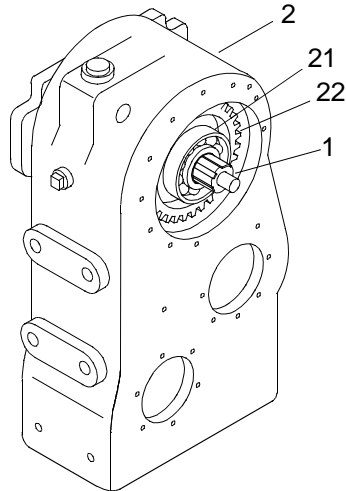

- t. Remove bearing (21) through large bore opening in transfer case (2).
 - u. Remove upper spur gear (22) through large bore opening in transfer case (2).
2. Remove intermediate shaft (23) from transfer case (2).

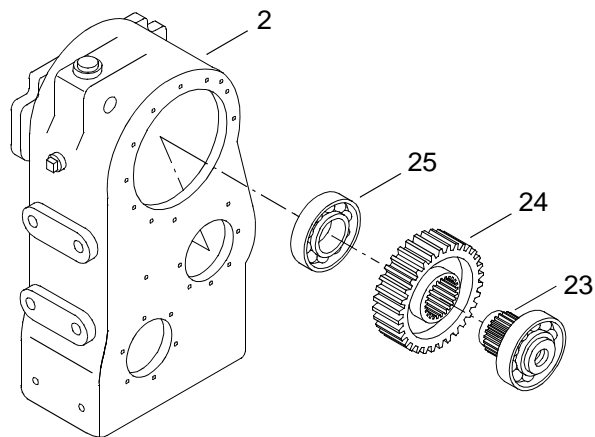

- a. Install slide hammer puller, from universal puller kit, into tapped hole in the intermediate shaft (23) and secure with the slide hammer puller locking nut.

WARNING

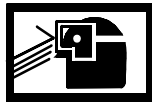

EYE PROTECTION

- b. Operate slide hammer and remove shaft (23).
- c. Slide intermediate spur gear (24) to large bore opening in the transfer case (2) and remove.
- d. Remove bearing (25) from center bore of transfer case (2).

{1} Place wooden blocks on arbor press.

{2} Position bearing (26) on wooden blocks.

WARNING



EYE PROTECTION



MOVING PARTS

{3} Press bearing (26) off of intermediate shaft (23) using an arbor press.

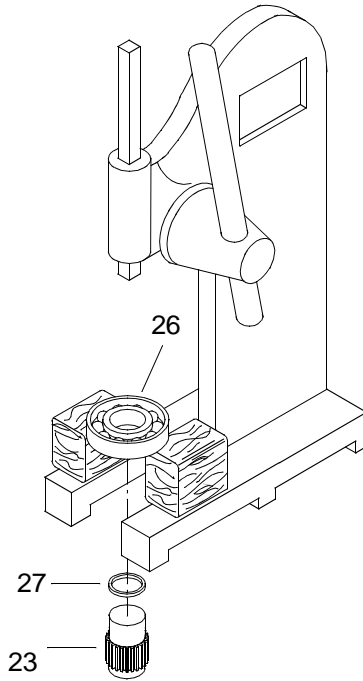

e. Remove spacer (27) from shaft (23).

3. Remove lower shaft (28) from transfer case (2).

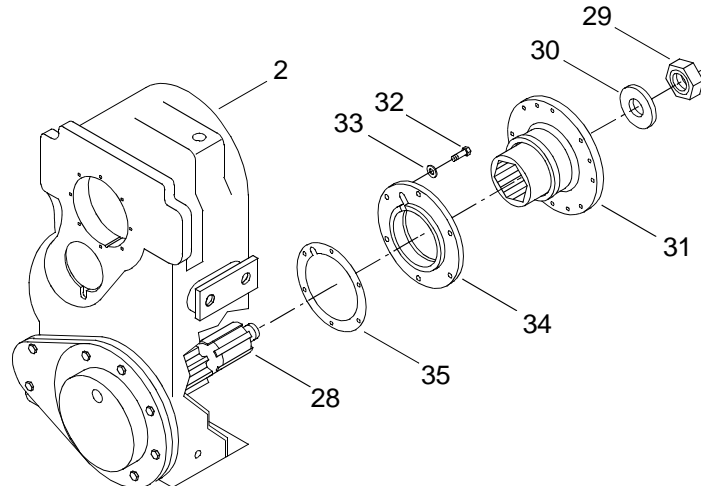

- a. Remove lock nut (29) and washer (30) from lower shaft (28).
- b. Remove flange (31) from lower shaft (28).
- c. Remove six cap screws (32) and lock washers (33) from bearing cap (34).
- d. Remove bearing cap (34).
- e. Remove and discard gasket (35).
- f. Place bearing cap (34) on wooden blocks.
- g. Using a brass drift and a hammer, remove input seal (36) from bearing cap (34).

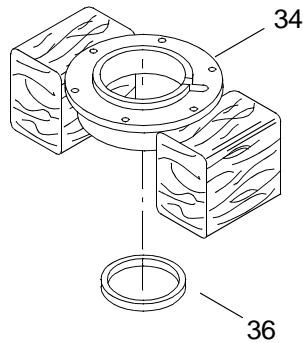

- h. Remove eight hex head cap screws (37) and lock washers (38).

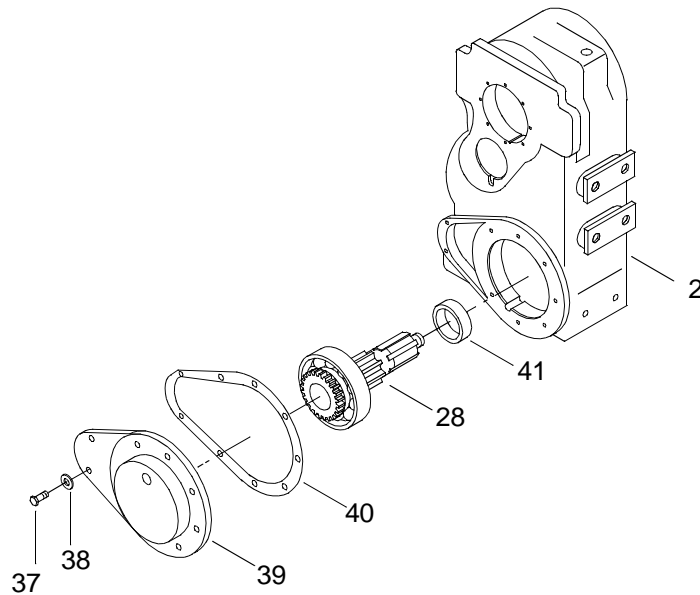

- i. Remove bearing cap (39).
- j. Remove and discard gasket (40).

WARNING

**EYE PROTECTION**

CAUTION

When driving out shaft, care should be taken not to damage threads or allow shaft to fall to the floor. Failure to comply could result in damage to equipment.

- k. Using a hand hammer, drive input shaft (28) out of transfer case (2).
- l. Remove spacer (41) from shaft (28).
- m. Place wooden blocks on arbor press.
- n. Place bearing (42) on wooden blocks.

WARNING

**EYE PROTECTION****MOVING PARTS**

- o. Press bearing (42) off of shaft (28).

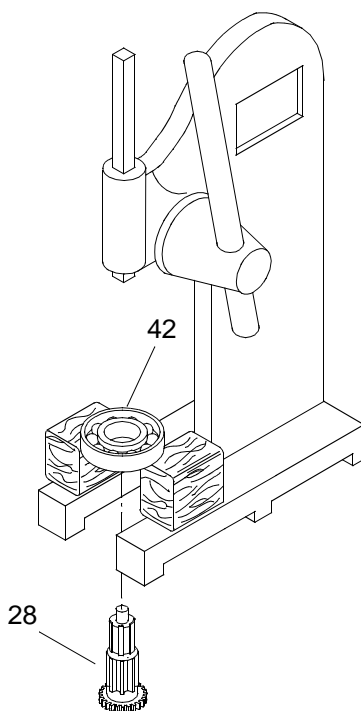

- p. Slide bearing (43) to large bore opening and remove.

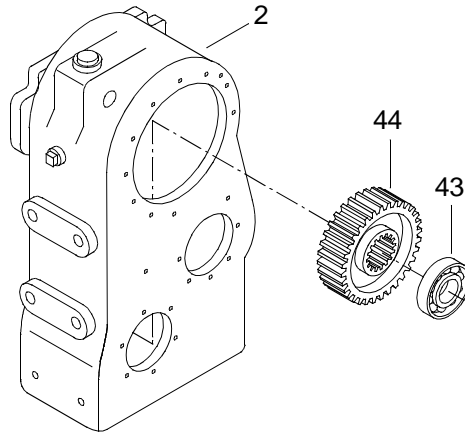

- q. Slide lower spur gear (44) to large bore opening and remove.

CLEAN TRANSFER CASE AND COMPONENTS

WARNING

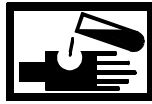

CHEMICAL

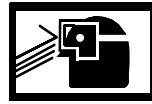

EYE PROTECTION

1. Clean spur gears, shafts and bearings. Use cleaner.

WARNING

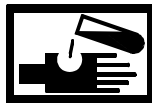

CHEMICAL

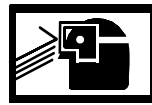

EYE PROTECTION

2. Clean interior of transfer case. Use cleaner.

WARNING

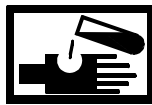

CHEMICAL



EYE PROTECTION

3. Clean gasket mounting areas to remove old material.

CAUTION

Do not use compressed air to spin bearings dry. Damage to mating surfaces will result due to lack of lubrication.

4. Dry components using a cleaning cloth.

INSPECT TRANSFER CASE AND COMPONENTS

1. Inspect interior and exterior of transfer case for cracks and corrosion. Replace transfer case if cracks are found.
2. Inspect bearing surfaces for discoloration, excessive wear, freedom of movement and pitting. Replace any damaged bearings.
3. Inspect spur gear teeth surfaces and edges for burrs, discoloration, excessive wear, nicks and pitting. Replace gears if damaged.
4. Inspect shaft splines for burrs, discoloration, excessive wear, nicks and pitting. Replace shafts if shaft splines are damaged.

ASSEMBLE THE TRANSFER CASE

1. Install lower shaft assembly (28).

WARNING

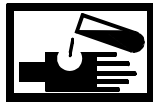
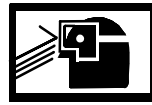
**CHEMICAL****EYE PROTECTION**

- a. Lubricate spur gear (44) with lubricating oil.

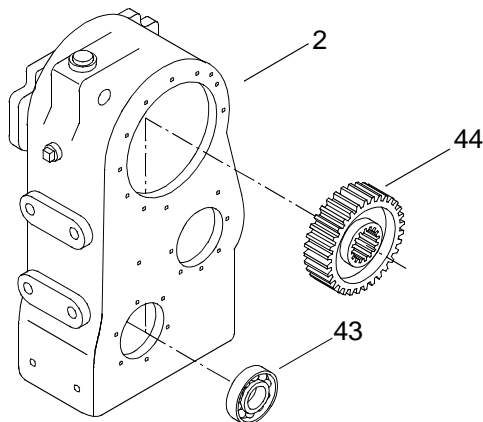

 WARNING



CHEMICAL

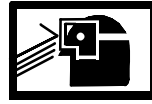

EYE PROTECTION

- b. Install lower spur gear (44) into transfer case (2), hub side up and slide into position.

 WARNING



CHEMICAL



EYE PROTECTION

- c. Lubricate bearing (43) with lubricating oil.

 WARNING



CHEMICAL



EYE PROTECTION

- d. Install bearing (43) into small bore of transfer case (2) using bearing driver and hand hammer. Recess approximately $\frac{1}{4}$ in.

 WARNING



CHEMICAL



EYE PROTECTION

- e. Lubricate the outer edge of new seal (36) with lubricating oil.

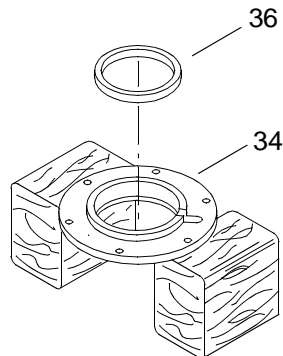

WARNING

**EYE PROTECTION**

- f. Using a brass drift and a hammer, install new seal (36) into bearing cap (34).
- g. Position new gasket (35) onto transfer case (2), aligning the lubricating groove with the extra hole in the gasket.

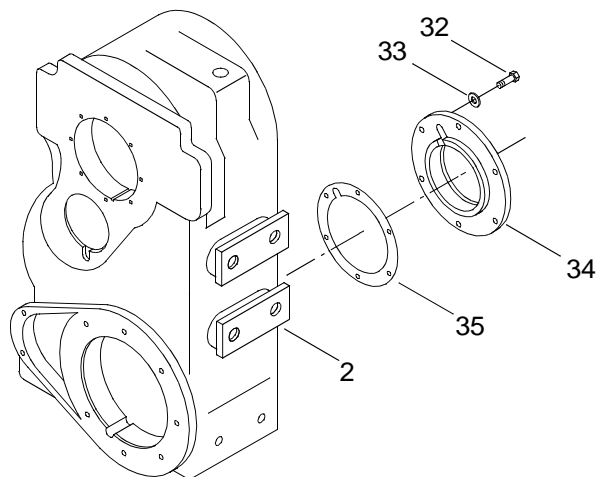

- h. Align oil groove in bearing cap (34) with oil groove in case (2) and install bearing cap (34).
- i. Install six cap screws (32) and lock washers (33).
- j. Using a torque wrench, torque screws (32) to 32-37 ft lbs (43-50 N-m).

WARNING

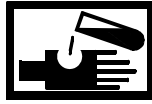
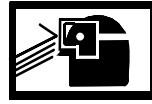
**CHEMICAL****EYE PROTECTION**

- k. Lubricate shaft (28) and bearing (42) with lubricating oil.

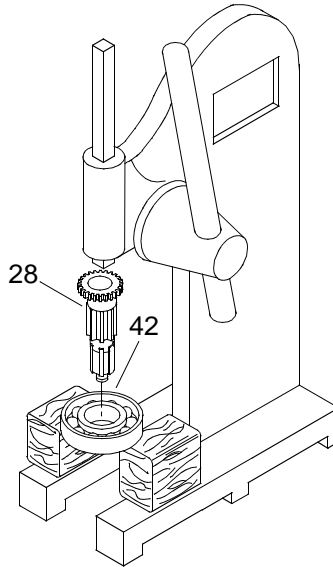

WARNING

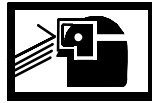
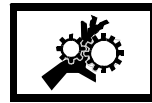
**EYE PROTECTION****MOVING PARTS**

- l. Using an arbor press, press shaft (28) into bearing (42).

WARNING

**CHEMICAL****EYE PROTECTION**

- m. Lubricate spacer (41) with lubricating oil.

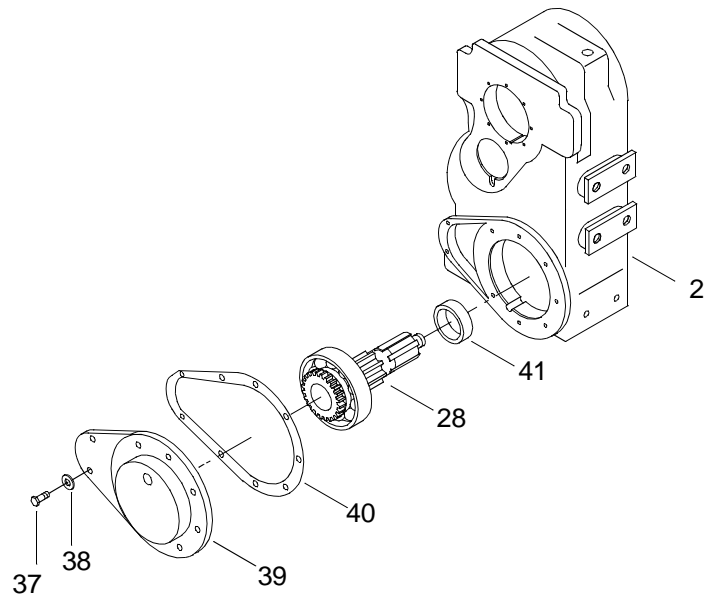

 WARNING



CHEMICAL

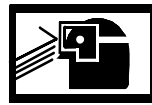

EYE PROTECTION

- n. Install spacer (41) onto shaft (28).

 WARNING

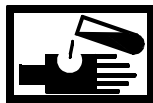

CHEMICAL



EYE PROTECTION

- o. Holding spacer (41) and bearing (42), turn shaft (28) over and position into gear (44).

 WARNING



EYE PROTECTION

- p. Install shaft (28) using a hand hammer.
- q. Position new gasket (40) on transfer case (2).
- r. Position bearing cap (39) on transfer case (2).
- s. Install eight hex head cap screws (37) and lock washers (38) to secure bearing cap (39).

WARNING

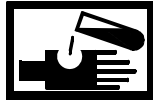
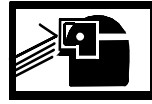
**CHEMICAL****EYE PROTECTION**

- t. Lubricate inner surface of flange (31) with lubricating oil.

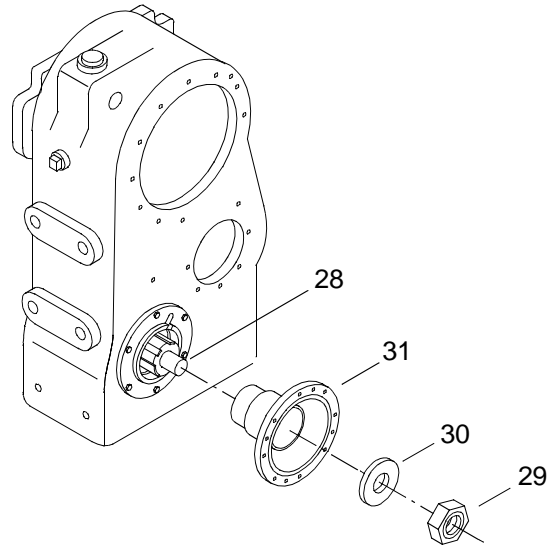

- u. Install flange (31) on lower shaft (28).
- v. Install new washer (30) and new lock nut (29) on lower shaft (28).
- w. Using a torque wrench, torque lock nut (29) to 430 ft lbs (583 N-m).

2. Install intermediate shaft (23).

- a. Position transfer case (2) with three bores up.

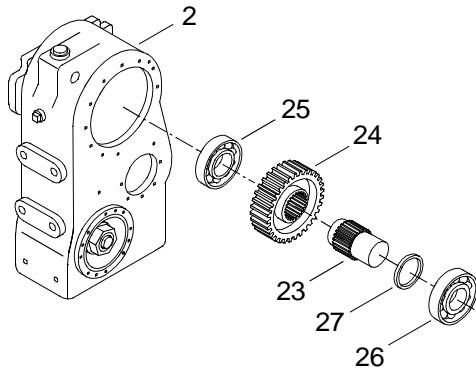

WARNING

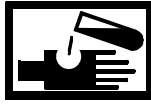
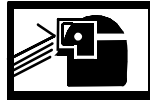
**CHEMICAL****EYE PROTECTION**

- b. Lubricate bearing (25) with lubricating oil.
- c. Using a bearing driver, install bearing (25) into center bore of transfer case (2) until it is seated in bearing bore.

WARNING

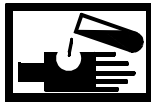
**CHEMICAL****EYE PROTECTION**

- d. Lubricate intermediate spur gear (24) with lubricating oil.
- e. Install intermediate spur gear (24), hub down, into large bore opening of transfer case (2) and slide to center of housing.

WARNING

**CHEMICAL****EYE PROTECTION**

- f. Lubricate intermediate shaft (23) splines with lubricating oil.

WARNING

**EYE PROTECTION**

- g. Install intermediate shaft (23) with threaded hole up using a hand hammer.

WARNING

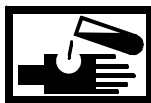
**CHEMICAL****EYE PROTECTION**

- h. Lubricate spacer (27) with lubricating oil.

- i. Install spacer (27) onto intermediate shaft (23).

WARNING



CHEMICAL

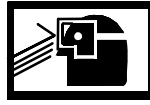

EYE PROTECTION

- j. Lubricate bearing (26) with lubricating oil.

WARNING



EYE PROTECTION

- k. Install bearing (26) onto intermediate shaft (23) using a bushing driver set and a hand hammer.

3. Install the upper shaft (1) on transfer case (2).

- a. Position cover (17) on wooden wedges.

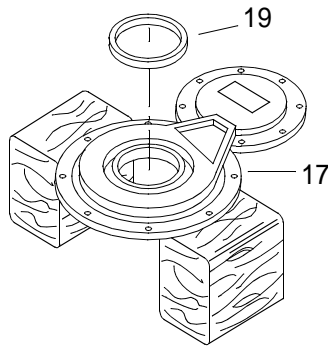

WARNING

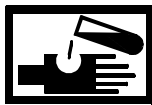

CHEMICAL



EYE PROTECTION

- b. Lubricate outer edge of new input oil seal (19) with lubricating oil.

WARNING



EYE PROTECTION

- c. Using a brass drift and a hand hammer, install upper input oil seal (19) in cover (17).

- d. Turn cover (17) over on wooden wedges.

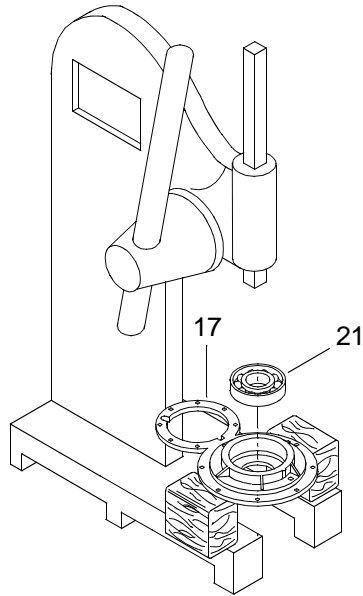

WARNING

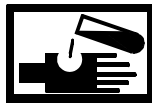

CHEMICAL



EYE PROTECTION

- e. Lubricate bearing (21) with lubricating oil.

WARNING

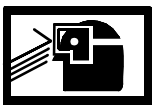

EYE PROTECTION

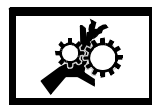

MOVING PARTS

- f. Using an arbor press, press bearing (21) into cover (17).

WARNING



CHEMICAL



EYE PROTECTION

- g. Lubricate upper spur gear (22) with lubricating oil.

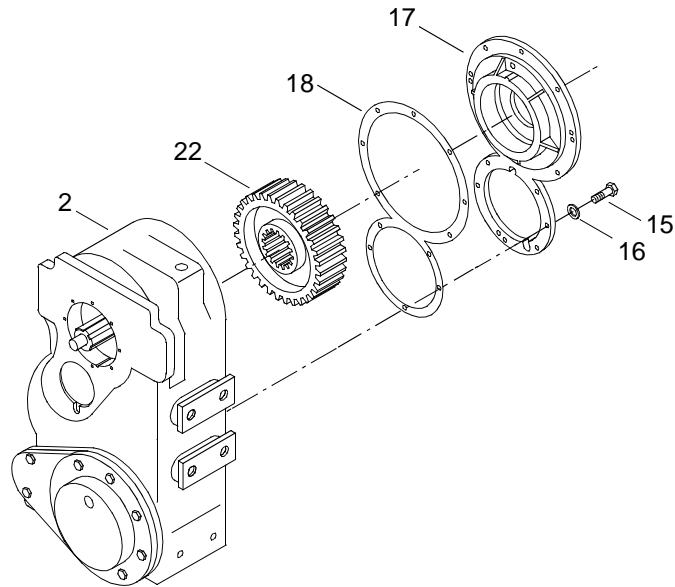

- h. Install upper input spur gear (22), hub up, into transfer case (2).
- i. Align bolt holes and position new gasket (18) on transfer case (2).
- j. Align bolt holes and position cover (17) on transfer case (2).
- k. Install 12 hex head cap screws (15) with washers (16).
- l. Using a torque wrench, torque hex head cap screws (15) to 35-40 ft lbs (47-54 N-m).
- m. Turn over transfer case (2).

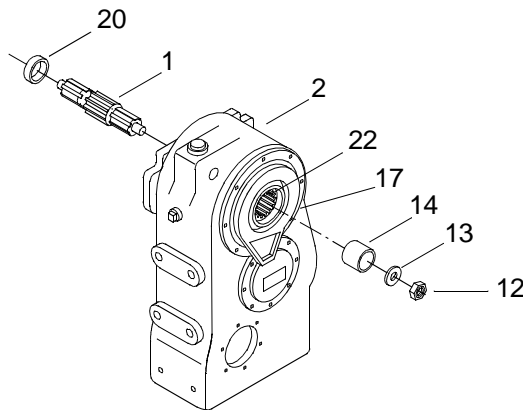

WARNING



CHEMICAL

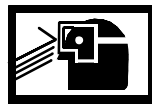

EYE PROTECTION

- n. Lubricate spacer (20) with lubricating oil.

-
- o. Install spacer (20) onto shaft (1).

WARNING



CHEMICAL



EYE PROTECTION

- p. Lubricate upper shaft (1) with lubricating oil.

WARNING

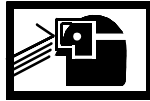

EYE PROTECTION

- q. Using a hand hammer, install shaft (1) in gear (22).

WARNING



CHEMICAL



EYE PROTECTION

- r. Lubricate spacer (14) with lubricating oil.
- s. Install spacer (14) on shaft (1).
- t. Install new washer (13) and new lock nut (12) on shaft (1).
- u. Position bearing cap (8) on wooden wedges.

WARNING



CHEMICAL



EYE PROTECTION

- v. Lubricate outer edge of new seal (10) with lubricating oil.

WARNING

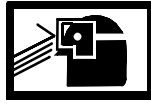
**EYE PROTECTION**

- w. Using a brass drift and a hammer, install new seal (10) into bearing cap (8).
- x. Turn bearing cap (8) over on wooden wedges.

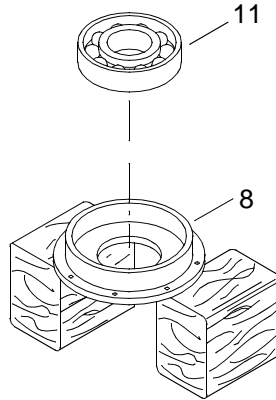

WARNING

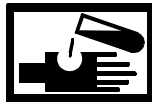
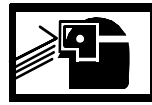
**CHEMICAL****EYE PROTECTION**

- y. Lubricate bearing (11) with lubricating oil.

WARNING

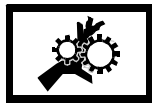
**MOVING PARTS****EYE PROTECTION**

- z. Using an arbor press, press bearing (11) into bearing cap (8).

- aa. Align bolt holes and oil groove and position new gasket (9) onto transfer case (2).

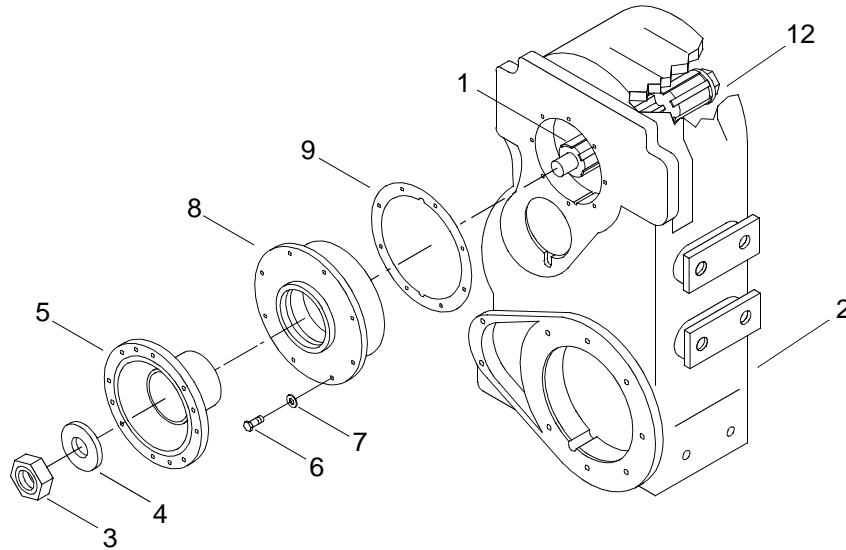

- ab. Align bolt holes and oil groove and position bearing cap (8) onto transfer case (2).
- ac. Use a hand hammer to tap into place.
- ad. Install six cap screws (6) and lock washers (7).
- ae. Using a torque wrench, torque cap screws (6) to 32-37 ft lbs (43-50 N-m).
- af. Install companion flange (5) on shaft (1).
- ag. Install new washer (4) and new lock nut (3) on shaft (1).
- ah. Using a torque wrench, torque lock nuts (3 and 12) to 430 ft lbs (583 N-m).

END OF WORK PACKAGE

**UNIT LEVEL MAINTENANCE
WARPING TUG
TRANSFER CASE BREATHER
REPLACEMENT**

INITIAL SETUP:**Tools**

Tool Kit, General Mechanic's (Rail and Marine) (Item 14, WP 0030 00)

Materials/Parts

Breather

(97271)

PN MJAHN110

Tape, Antiseize (Item 9, WP 0029 00)

Personnel Required

Engineer 88L

References

TM 55-1945-205-10-3

Equipment Condition

Propulsion Module Ventilated. (TM 55-1945-205-24-3-1)

REMOVE TRANSFER CASE BREATHER

1. Verify disconnect circuit breaker (1) on A10 panel is positioned to OFF.

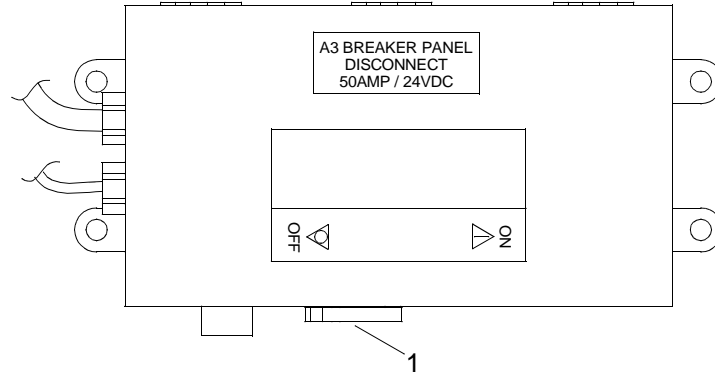

-
- Remove breather (2) from transfer case (3).

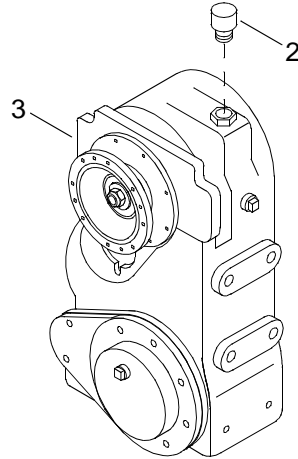

- Discard breather (2).

INSTALL TRANSFER CASE BREATHER

- Apply antiseize tape to threads of new breather (2).
- Install new breather (2) into transfer case (3).
- Tighten new breather (2).
- Perform operational check of drive train. (TM 55-1945-205-10-3)

END OF WORK PACKAGE

**UNIT LEVEL MAINTENANCE
WARPING TUG
TRANSFER CASE LUBE PUMP
REPLACEMENT**

INITIAL SETUP:**Tools**

Tool Kit, General Mechanic's (Rail and Marine) (Item 14, WP 0030 00)
Wrench, Torque (0-175 ft lbs) (Item 16, WP 0030 00)
Goggles, Industrial (Item 7, WP 0030 00)
Gloves, Chemical (Item 5, WP 0030 00)
Apron, Utility (Item 1, WP 0030 00)
Pan, Drain (Item 9, WP 0030 00)

Materials/Parts

Lubrication Pump
(97271)
PN H378889-1
Pump Gasket
(97271)
PN H22-P-54
Shim
(97271)
PN H738-228-1
Shim
(97271)
PN H738-228-2
Screw, Round Head
(97271)
PN H450641
Cloth, Cleaning (Item 4, WP 0029 00)
Spill Clean-Up Kit, Hazardous Material (Item 6, WP 0029 00)

Personnel Required

Engineer 88L

References

TM 55-1945-205-10-3

Equipment Condition

Propulsion Module Ventilated. (TM 55-1945-205-24-3-1)

REMOVE LUBE PUMP

1. Verify disconnect circuit breaker (2) on A10 panel is positioned to OFF.

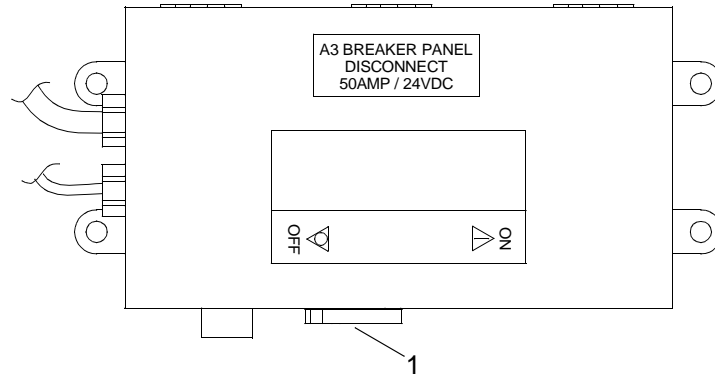

2. Tag hoses as intake (2) and outlet (3) to aid in assembly.

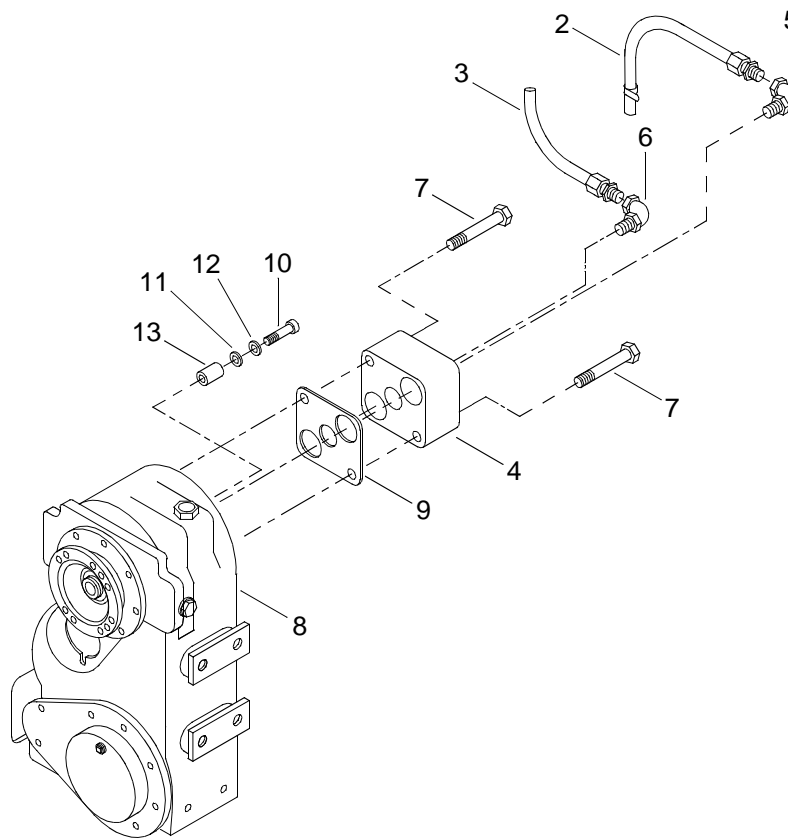

3. Place drain pan under transfer case lube pump (4).

WARNING

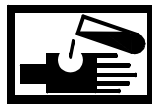

CHEMICAL

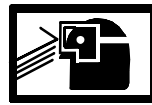

EYE PROTECTION

4. Disconnect intake lubricant hose (2) from elbow fitting (5).

WARNING

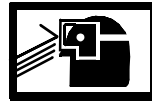
**CHEMICAL****EYE PROTECTION**

5. Disconnect outlet lubricant hose (3) from elbow fitting (6).

WARNING

**CHEMICAL****EYE PROTECTION**

6. Remove elbow fitting (5) from lube pump (4).

WARNING

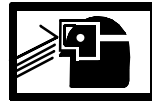
**CHEMICAL****EYE PROTECTION**

7. Remove elbow fitting (6) from lube pump (4).
8. Remove two bolts (7) from lube pump (4).

WARNING

**CHEMICAL****EYE PROTECTION**

9. Remove lube pump (4) from transfer case housing (8) and discard.

WARNING

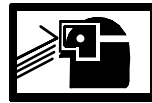
**CHEMICAL****EYE PROTECTION**

10. Remove and discard old gasket (9).
11. Remove round head screw (10), two shims (11 and 12) and coupling (13) from transfer case housing (8).

CLEAN TRANSFER CASE HOUSING

1. Place a clean cloth inside the transfer case housing (8) to prevent gasket pieces from entering the housing during cleaning.

WARNING

**EYE PROTECTION**

2. Using a wire brush, clean old gasket material from surface of transfer case housing (8).

INSPECT DRIVE SCREW COUPLING

1. Inspect round head screw (10) head and threads for damage. If found, replace damaged item.
2. Inspect coupling (13) for pitting or scoring. If found, replace damaged item.

INSTALL LUBE PUMP

1. Install round head screw (10), one .010 in. shim (11), one 0.050 in. shim (12) and coupling (13).
2. Tighten round head screw (10).
3. Position new lube pump (4) and new gasket (9) on transfer case housing (8).
4. Install two bolts (7) through transfer case housing (8) and gasket (9).
5. Using a torque wrench, torque two bolts (7) to 14-16 ft lbs (19-22 N-m).
6. Install elbow fitting (6) on lube pump (4).
7. Install elbow fitting (5) on lube pump (4).
8. Connect outlet lubricant hose (3) on elbow fitting (6).
9. Connect intake lubricant hose (2) on elbow fitting (5).
10. Remove tags from hoses.

WARNING

**CHEMICAL****EYE PROTECTION**

11. Remove drain pan and dispose of contents in accordance with local procedures.

WARNING

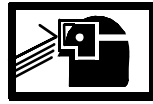
**CHEMICAL****EYE PROTECTION****SLICK FLOOR**

12. Clean up spilled fluid with a spill kit and dispose of spill kit waste in accordance with local procedures.
13. Perform operational check of drive train. (TM 55-1945-205-10-3)

END OF WORK PACKAGE

**UNIT LEVEL MAINTENANCE
WARPING TUG
TRANSFER CASE OIL COOLER LINES
REPLACEMENT**

INITIAL SETUP:**Tools**

Tool Kit, General Mechanic's (Rail and Marine) (Item 14, WP 0030 00)
 Pan, Drain (Item 9, WP 0030 00)
 Goggles, Industrial (Item 7, WP 0030 00)
 Gloves, Chemical (Item 5, WP 0030 00)

Materials/Parts

Hose Assembly
 (87373)
 PN 2010606-8-8-8-24
 Hose Assembly
 (87373)
 PN 2013939-8-8-8-72
 Spill Clean-Up Kit, Hazardous Material (Item 6, WP 0029 00)

Personnel Required

Engineer 88L

References

TM 55-1945-205-10-3

Equipment Condition

Transfer Case Drained. (WP 0013 00)
 Propulsion Module Ventilated. (TM 55-1945-205-24-3-1)

REMOVE TRANSFER CASE OIL COOLER LINES**NOTE**

This task is typical for both port and starboard transfer case oil cooler lines.

1. Verify disconnect circuit breaker (1) on A10 panel is positioned to OFF.

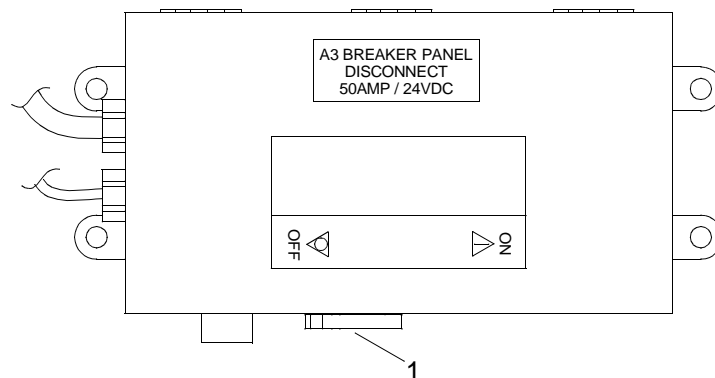

2. Position drain pan next to oil cooler and under transfer case oil lines.

 WARNING



CHEMICAL

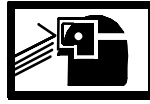

EYE PROTECTION

3. Disconnect transfer case outlet hose (2) from transfer case outlet nipple (3).

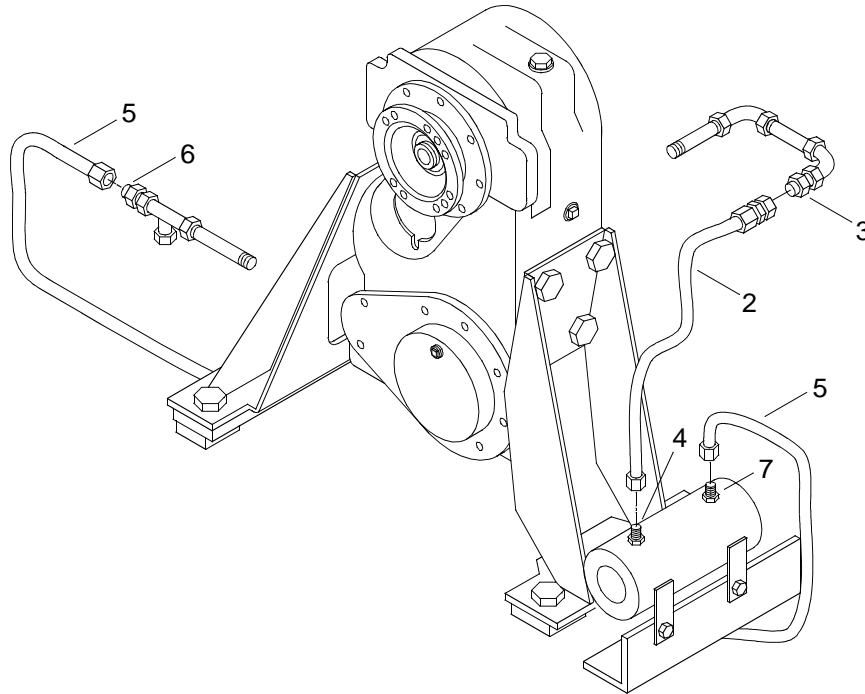

 WARNING



CHEMICAL

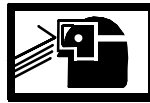

EYE PROTECTION

4. Disconnect transfer case outlet hose (2) from transfer case oil cooler inlet nipple (4).
5. Remove and discard transfer case outlet hose (2).

 WARNING



CHEMICAL



EYE PROTECTION

6. Disconnect transfer case inlet hose (5) from transfer case inlet nipple (6).

 WARNING



CHEMICAL

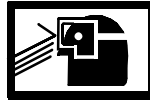

EYE PROTECTION

7. Disconnect transfer case inlet hose (5) from transfer case oil cooler outlet nipple (7).
8. Remove and discard transfer case inlet hose (5).

INSTALL TRANSFER CASE OIL COOLER LINES

1. Position new transfer case inlet hose (5).
2. Connect transfer case inlet hose (5) to transfer case oil cooler outlet nipple (7).
3. Connect transfer case inlet hose (5) to transfer case inlet nipple (6).
4. Tighten transfer case inlet hose (5).
5. Position new transfer case outlet hose (2).
6. Connect transfer case outlet hose (2) to transfer case oil cooler inlet nipple (4).
7. Connect transfer case outlet hose (2) to transfer case outlet nipple (3).
8. Tighten transfer case outlet hose (2).
9. Service transfer case. (WP 0013 00)

 WARNING



CHEMICAL

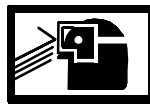

EYE PROTECTION

10. Remove drain pan and dispose of contents in accordance with local procedures.

 WARNING



CHEMICAL



EYE PROTECTION



SLICK FLOOR

11. Clean up spilled fluid with a spill kit and dispose of spill kit waste in accordance with local procedures.
12. Perform operational check of drive train. (TM 55-1945-205-10-3)

END OF WORK PACKAGE

**UNIT LEVEL MAINTENANCE
WARPING TUG
TRANSFER CASE OIL COOLER
REPLACEMENT**

INITIAL SETUP:**Tools**

Tool Kit, General Mechanic's (Rail and Marine) (Item 14, WP 0030 00)
 Gloves, Chemical (Item 5, WP 0030 00)
 Goggles, Industrial (Item 7, WP 0030 00)
 Pan, Drain (Item 9, WP 0030 00)

Materials/Parts

Oil Cooler
 (0ANA7)
 PN 1377-1-7
 Antiseize Compound (Item 1, WP 0029 00)
 Spill Clean-Up Kit, Hazardous Material (Item 6, WP 0029 00)

Personnel Required

Engineer 88L

References

TM 55-1945-205-10-3

Equipment Condition

Transfer Case Drained. (WP 0013 00)
 Propulsion Module Ventilated. (TM 55-1945-205-24-3-1)

REMOVE TRANSFER CASE OIL COOLER**NOTE**

This task is typical for both port and starboard transfer case oil coolers.

1. Verify disconnect circuit breaker (1) on A10 panel is positioned to OFF.

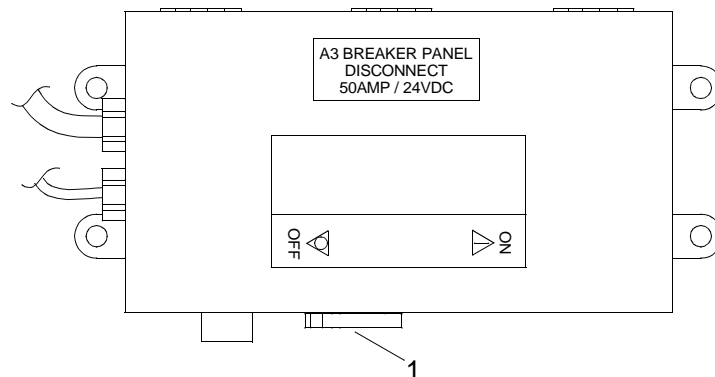

- Verify that the butterfly valve (2) on sea chest is turned to the off position.

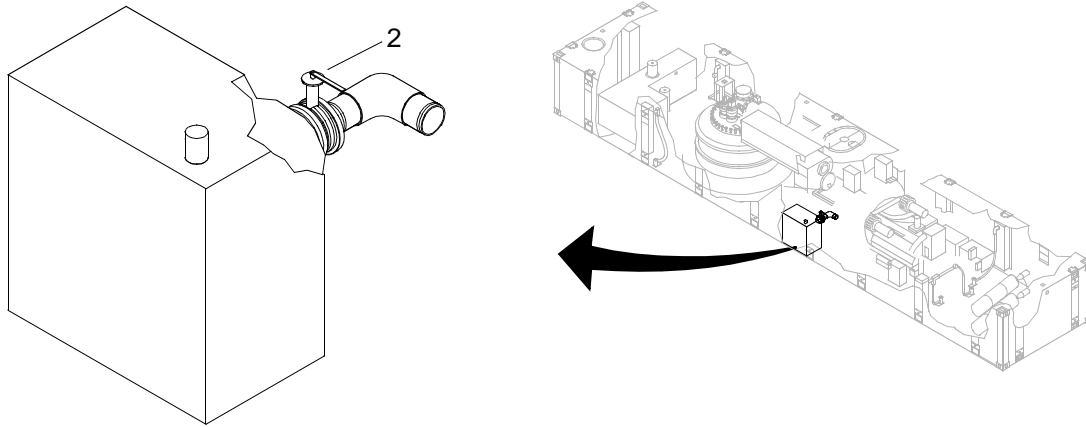

- Place drain pan under oil cooler lines.

WARNING

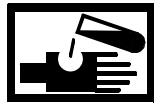

CHEMICAL

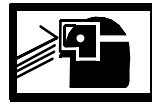

EYE PROTECTION

- Disconnect hose assembly (3) at oil cooler outlet (4).

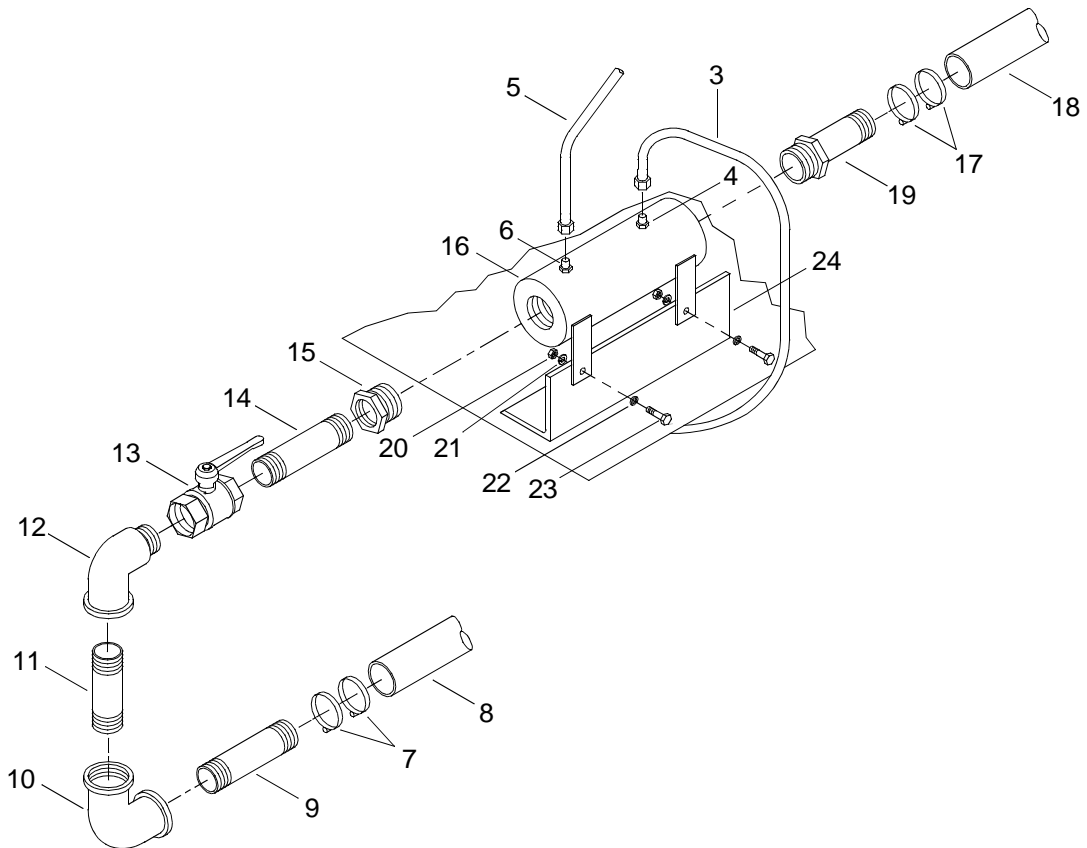

WARNING

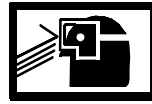
**CHEMICAL****EYE PROTECTION**

5. Disconnect hose assembly (5) at oil cooler inlet (6).
6. Loosen clamps (7).
7. Disconnect hose (8) from nipple (9).
8. Disconnect nipple (9) from elbow (10).
9. Remove elbow (10) from nipple (11).
10. Remove nipple (11) from street elbow (12).
11. Remove street elbow (12) from ball valve (13).
12. Remove ball valve (13) from nipple (14).
13. Remove nipple (14) from reducer (15).
14. Remove reducer (15) from cooler (16).
15. Loosen clamps (17) and disconnect hose (18).
16. Disconnect reducer (19) from cooler (16).
17. Remove two hex head nuts (20), two lock washers (21), two hex head cap screws (22) and two flat washers (23) securing oil cooler (16) to foundation (24).
18. Discard oil cooler (16).

INSTALL TRANSFER CASE OIL COOLER

1. Position new oil cooler (16) on foundation (24).
2. Install two hex head cap screws (22), two flat washers (23), two lock washers (21) and two hex head nuts (20).
3. Tighten nuts (20).
4. Wrap threads of reducer (19) with antiseize tape.
5. Install reducer (19) on the cooler (16).
6. Position hose (18) on reducer (19).
7. Install clamps (17) on hose (18).
8. Tighten hose clamps (17).

9. Wrap threads of reducer (15) with antiseize tape.
10. Install reducer (15) on cooler (16).
11. Wrap threads of nipple (14) with antiseize tape.
12. Install nipple (14) on reducer (15).
13. Install ball valve (13) on nipple (14).
14. Wrap threads of street elbow (12) with antiseize tape.
15. Install street elbow (12) on ball valve (13).
16. Wrap threads of nipple (11) with antiseize tape.
17. Install nipple (11) on street elbow (12).
18. Install elbow (10) on nipple (11).
19. Wrap threads of nipple (9) with antiseize tape.
20. Install nipple (9) on elbow (10).
21. Install hose (8) on nipple (9).
22. Install clamps (7) on hose (8).
23. Tighten clamps (7).
24. Connect hose assembly (5) to oil cooler inlet (6).
25. Connect hose assembly (3) to oil cooler outlet (2).
26. Service transfer case. (WP 0013 00)

WARNING

**CHEMICAL****EYE PROTECTION**

27. Remove drain pan and dispose of contents in accordance with local procedures.

WARNING

**CHEMICAL****EYE PROTECTION****SLICK FLOOR**

28. Clean up spilled fluid with a spill kit and dispose of spill kit waste in accordance with local procedures.
29. Perform operational check of drive train. (TM 55-1945-205-10-3)

END OF WORK PACKAGE

**DIRECT SUPPORT MAINTENANCE
WARPING TUG
TRANSFER CASE UPPER INPUT OIL SEAL
REPLACEMENT**

INITIAL SETUP:**Tools**

Tool Kit, General Mechanic's (Item 13, WP 0030 00)
Puller Kit, Universal (Item 11, WP 0030 00)
Bushing Driver Set (Item 3, WP 0030 00)
Wrench, Torque (100-600 ft lb) (Item 17, WP 0030 00)
Goggles, Industrial (Item 7, WP 0030 00)
Gloves, Chemical (Item 5, WP 0030 00)
Apron, Utility (Item 1, WP 0030 00)
Pan, Drain (Item 9, WP 0030 00)

Materials/Parts

Seal, Plain3
(97271)
PN H60-463-7
NSN 5330-01-283-4140
Lubricating Oil, Engine (Item 5, WP 0029 00)
Cleaner (Item 3, WP 0029 00)
Spill Clean-Up Kit, Hazardous Material (Item 6, WP 0029 00)

Personnel Required

Engineer 88L

References

TM 55-1945-205-10-3

Equipment Condition

Transfer Case Lube Pump Removed. (WP 0017 00)

REMOVE OIL SEAL

1. Place drain pan under transfer case (1).

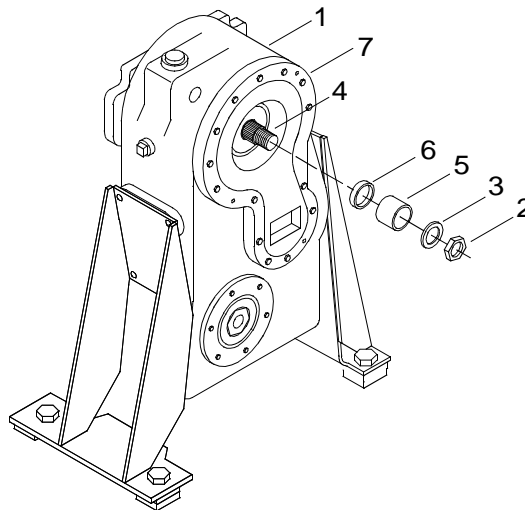

2. Remove lock nut (2) and washer (3) from upper input shaft (4).
3. Remove spacer (5) from upper input shaft (4).

 WARNING



CHEMICAL



EYE PROTECTION

4. Using a seal puller from the puller kit, remove oil seal (6) from bearing cap flange (7) and discard.

 WARNING

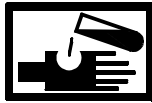

CHEMICAL

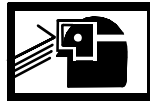

EYE PROTECTION

5. Remove drain pan and dispose of contents in accordance with local procedures.

INSTALL OIL SEAL

 WARNING

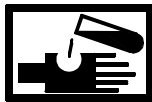

CHEMICAL



EYE PROTECTION

1. Clean dirt and debris from oil seal seat in bearing cap (7). Use cleaner.

 WARNING



CHEMICAL



EYE PROTECTION

2. Lightly coat new oil seal (6) with lubricating oil.
3. Using a bushing driver set, install new seal (6) into bearing cap (7).
4. Install spacer (5) on upper input shaft (4).
5. Install flat washer (3) and lock nut (2).
6. Using torque wrench, torque nut (2) to 430 ft lbs (583 N-m).

WARNING

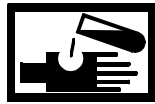
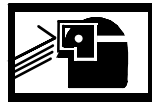
**CHEMICAL****EYE PROTECTION****SLICK FLOOR**

7. Clean up any spilled oil with a spill kit and dispose of spill kit waste in accordance with local procedures.
8. Install transfer case lube pump. (WP 0017 00)
9. Perform operational check of drive train. (TM 55-1945-205-10-3)

END OF WORK PACKAGE

**DIRECT SUPPORT MAINTENANCE
WARPING TUG
TRANSFER CASE UPPER OUTPUT OIL SEAL
REPLACEMENT**

INITIAL SETUP:**Tools**

Tool Kit, General Mechanic's (Item 13, WP 0030 00)
Puller Kit, Universal (Item 11, WP 0030 00)
Bushing Driver Set (Item 3, WP 0030 00)
Wrench, Torque (100-600 ft lbs) (Item 17, WP 0030 00)
Gloves, Chemical (Item 5, WP 0030 00)
Goggles, Industrial (Item 7, WP 0030 00)
Apron, Utility (Item 1, WP 0030 00)
Pan, Drain (Item 9, WP 0030 00)

Materials/Parts

Seal, Plain
(97271)
NSN 5330-01-283-4140
PN H60-463-7
Lubricating Oil, Engine (Item 5, WP 0029 00)
Cleaner (Item 3, WP 0029 00)
Spill Clean-Up Kit, Hazardous Material (Item 6, WP 0029 00)

Personnel Required

Engineer 88L

References

TM 55-1945-205-10-3

Equipment Condition

Main Mast Navigation Assembly Removed. (TM 55-1945-205-24-3-1)
SINCGARS Radio Antenna Removed. (TM 11-5820-890-10-8)
Powered Section Operators Cab Removed. (TM 55-1945-205-24-3-1)
Powered Section Intake Plenum Assembly Removed. (TM 55-1945-205-24-3-1)
Powered Section Engine Hatch Removed. (TM 55-1945-205-24-3-1)
Drive Train Transfer Case To Pump-Jet Machinery Guards Removed. (TM 55-1945-205-24-3-1)
Drive Train Marine Gear To Transfer Case Machinery Guards Removed. (TM 55-1945-205-24-3-1)

REMOVE OIL SEAL

1. Place drain pan under transfer case (1).
2. Remove lock nut (2) and washer (3) from upper output shaft (4).

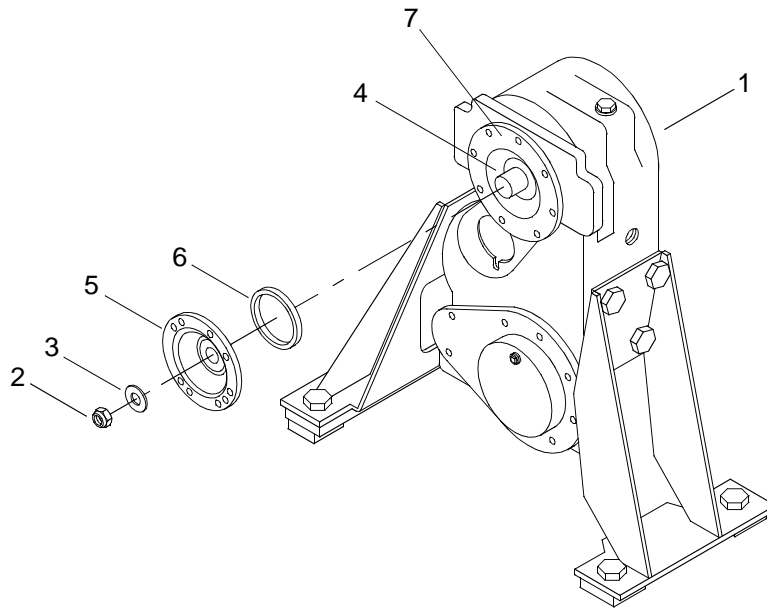

- Remove companion flange (5) from upper output shaft (4).

WARNING



CHEMICAL



EYE PROTECTION

- Using a seal puller from the universal puller kit, remove oil seal (6) from bearing cap (7) and discard.

INSTALL OIL SEAL

WARNING



CHEMICAL



EYE PROTECTION

- Using cleaner, clean dirt and debris from oil seal seat in bearing cap (7).

WARNING



CHEMICAL



EYE PROTECTION

- Lightly coat new oil seal (6) with lubricating oil.
- Using a bushing driver set, install new seal (6) into bearing cap (7).

-
4. Install companion flange (5) on upper output shaft (4).
 5. Install flat washer (3) and lock nut (2).
 6. Using torque wrench, torque nut (2) to 430 ft lbs (583 N-m).

WARNING



CHEMICAL



EYE PROTECTION

7. Remove drain pan and dispose of contents in accordance with local procedures.

WARNING



CHEMICAL



EYE PROTECTION



SLICK FLOOR

8. Clean up spilled fluid with a spill kit and dispose of spill kit waste in accordance with local procedures.
9. Install drive train marine gear to transfer case machinery guards. (TM 55-1945-205-24-3-1)
10. Install drive train transfer case to pump-jet machinery guards. (TM 55-1945-205-24-3-1)
11. Install powered section engine hatch. (TM 55-1945-205-24-3-1)
12. Install powered section intake plenum assembly. (TM 55-1945-205-24-3-1)
13. Install powered section operators cab. (TM 55-1945-205-24-3-1)
14. Install SINCGARS radio antenna. (TM 11-5820-890-10-8)
15. Install main mast navigation assembly. (TM 55-1945-205-24-3-1)
16. Perform operational check of drive train. (TM 55-1945-205-10-3)

END OF WORK PACKAGE

**DIRECT SUPPORT MAINTENANCE
WARPING TUG
TRANSFER CASE LOWER INPUT OIL SEAL
REPLACEMENT**

INITIAL SETUP:**Tools**

Tool Kit, General Mechanic's (Item 13, WP 0030 00)
 Puller Kit, Universal (Item 11, WP 0030 00)
 Bushing Driver Set (Item 3, WP 0030 00)
 Wrench, Torque (100-600 ft lbs) (Item 17, WP 0030 00)
 Apron, Utility (Item 1, WP 0030 00)
 Goggles, Industrial (Item 7, WP 0030 00)
 Gloves, Chemical (Item 5, WP 0030 00)

Materials/Parts

Seal, Plain
 (97271)
 NSN 5330-01-283-4140
 PN H60-463-7
 Lubricating Oil, Engine (Item 5, WP 0029 00)
 Cleaner (Item 3, WP 0029 00)

Personnel Required

Engineer 88L

References

TM 55-1945-205-10-3

Equipment Condition

Main Mast Navigation Assembly Removed. (TM 55-1945-205-24-3-1)
 SINGARS Radio Antenna Removed. (TM 11-5820-890-10-8)
 Powered Section Operators Cab Removed. (TM 55-1945-205-24-3-1)
 Powered Section Intake Plenum Assembly Removed. (TM 55-1945-205-24-3-1)
 Powered Section Engine Hatch Removed. (TM 55-1945-205-24-3-1)
 Drive Train Marine Gear To Transfer Case Machinery Guard Removed. (TM 55-1945-205-24-3-1)
 Drive Train Marine Gear To Transfer Case Drive Shaft Removed. (TM 55-1945-205-24-3-1)
 Transfer Case Drained. (WP 0013 00)

REMOVE OIL SEAL

1. On transfer case (1), remove lock nut (2) and washer (3) from lower input shaft (4).

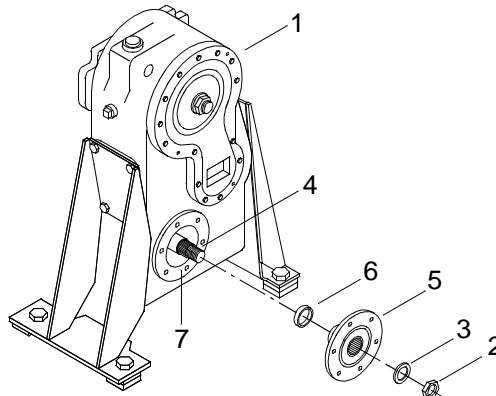

-
- Remove companion flange (5) from lower input shaft (4).

WARNING



CHEMICAL

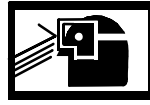

EYE PROTECTION

- Using a seal puller from the universal puller kit, remove the old oil seal (6) from bearing cap flange (7) and discard.

INSTALL OIL SEAL

WARNING



CHEMICAL

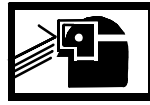

EYE PROTECTION

- Clean dirt and debris from oil seal seat in bearing cap (7). Use cleaner.

WARNING



CHEMICAL

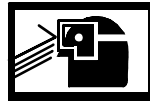

EYE PROTECTION

- Lightly coat new oil seal (6) with lubricating oil.
- Using a bushing driver set, install new seal (6) into bearing cap (7).
- Install spacer (5) on lower input shaft (4).
- Install flat washer (3) and lock nut (2).
- Using a torque wrench, torque nut (2) to 430 ft lbs (583 N-m).
- Service transfer case. (WP 0013 00)
- Install drive train marine gear to transfer case drive shaft. (TM 55-1945-205-24-3-1)
- Install drive train marine gear to transfer case machinery guard. (TM 55-1945-205-24-3-1)
- Install powered section engine hatch. (TM 55-1945-205-24-3-1)
- Install powered section intake plenum assembly. (TM 55-1945-205-24-3-1)
- Install powered section operators cab. (TM 55-1945-205-24-3-1)
- Install SINCGARS radio antenna. (TM 11-5820-890-10-8)
- Install main mast navigation assembly. (TM 55-1945-205-24-3-1)
- Perform operational check of drive train. (TM 55-1945-205-10-3)

END OF WORK PACKAGE

**DIRECT SUPPORT MAINTENANCE
WARPING TUG
TRANSFER CASE BEARING CAP COVER GASKET
REPLACEMENT**

INITIAL SETUP:**Tools**

Tool Kit, General Mechanic's (Item 13, WP 0030 00)
Wrench, Torque (0-175 ft lbs) (Item 16, WP 0030 00)
Goggles, Industrial (Item 7, WP 0030 00)
Gloves, Chemical (Item 5, WP 0030 00)
Apron, Utility (Item 1, WP 0030 00)

Materials/Parts

Gasket, Cover
(97271)
NSN 5330-01-283-5427
PN H738-223-3
Cleaner (Item 3, WP 0029 00)

Personnel Required

Engineer 88L

References

TM 55-1945-205-10-3

Equipment Condition

Main Mast Navigation Assembly Removed. (TM 55-1945-205-24-3-1)
SINGARS Radio Antenna Removed. (TM 11-5820-890-10-8)
Powered Section Operators Cab Removed. (TM 55-1945-205-24-3-1)
Powered Section Intake Plenum Assembly Removed. (TM 55-1945-205-24-3-1)
Powered Section Engine Hatch Removed. (TM 55-1945-205-24-3-1)
Drive Train Transfer Case To Pump-Jet Machinery Guard Removed. (TM 55-1945-205-24-3-1)
Drive Train Transfer Case To Pump-Jet Drive Shaft Removed. (TM 55-1945-205-24-3-1)
Transfer Case Drained. (WP 0013 00)

REMOVE BEARING CAP COVER GASKET

1. On transfer case (1), remove nine hex head cap screws (2) and lock washers (3) from bearing cap cover (4).

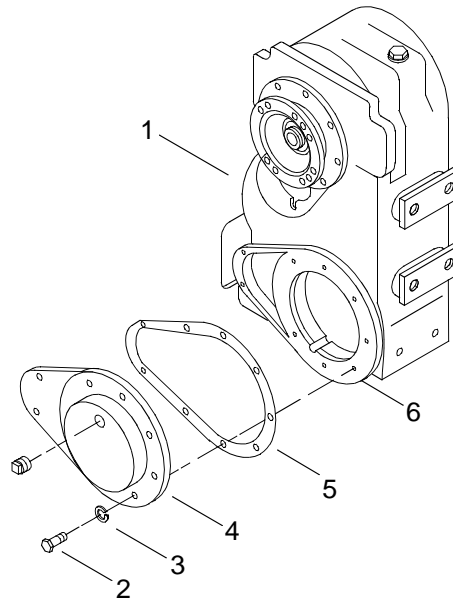

WARNING



CHEMICAL

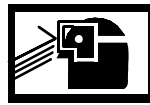

EYE PROTECTION

2. Remove bearing cap cover (4) and gasket (5). Discard gasket (5).

CLEAN BEARING CAP COVER

WARNING



CHEMICAL

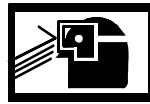

EYE PROTECTION

1. Using cleaner, clean bearing cap cover (4).

WARNING



CHEMICAL



EYE PROTECTION

2. Using cleaner, clean transfer case flange (6).

INSPECT BEARING CAP COVER

1. Inspect bearing cap cover (4) for any cracks or damage. If found, replace cover.
2. Inspect transfer case flange (6) for any cracks or damage. If found, replace transfer case.

INSTALL BEARING CAP COVER GASKET

1. Install new gasket (5) on transfer case flange (6).
2. Install bearing cap cover (4) on transfer case flange (6).
3. Install nine hex head cap screws (2) and lock washers (3).
4. Using torque wrench, torque cap screws (2) to 34-40 ft lbs (47-54 N-m).
5. Service transfer case. (WP 0013 00)
6. Install drive train transfer case to pump-jet drive shaft. (TM 55-1945-205-24-3-1)
7. Install drive train transfer case to pump-jet machinery guard. (TM 55-1945-205-24-3-1)
8. Install powered section engine hatch. (TM 55-1945-205-24-3-1)
9. Install powered section intake plenum assembly. (TM 55-1945-205-24-3-1)
10. Install powered section operators cab. (TM 55-1945-205-24-3-1)
11. Install SINCGARS radio antenna. (TM 11-5820-890-10-8)
12. Install main mast navigation assembly. (TM 55-1945-205-24-3-1)
13. Perform operational check of drive train. (TM 55-1945-205-10-3)

END OF WORK PACKAGE

**DIRECT SUPPORT MAINTENANCE
WARPING TUG
TRANSFER CASE
PREPARATION FOR STORAGE OR SHIPMENT**

INITIAL SETUP:**Tools**

Tool Kit, General Mechanic's (Item 13, WP 0030 00)
 Pan, Drain (Item 9, WP 0030 00)
 Gloves, Chemical (Item 5, WP 0030 00)
 Goggles, Industrial (Item 7, WP 0030 00)
 Sling, Engine and Transmission, Motor Vehicle (Item 12, WP 0030 00)

Materials/Parts

Lubricating Oil, Engine (Item 5, WP 0029 00)
 Qty 6
 Tags, Shipping (Red) (Item 7, WP 0029 00)
 Tags, Shipping (Yellow) (Item 8, WP 0029 00)
 Bag, Plastic (Item 2, WP 0029 00)
 Spill Clean-Up Kit, Hazardous Material (Item 6, WP 0029 00)

Personnel Required

Engineer 88L

Equipment Condition

Propulsion Module Dry-Docked.
 Main Mast Navigation Assembly Removed. (TM 55-1945-205-24-3-1)
 SINCGARS Radio Antenna Removed. (TM 11-5820-890-10-8)
 Powered Section Operators Cab Removed. (TM 55-1945-205-24-3-1)
 Powered Section Intake Plenum Assembly Removed. (TM 55-1945-205-24-3-1)
 Powered Section Engine Hatch Removed. (TM 55-1945-205-24-3-1)
 Drive Train Transfer Case To Pump-Jet Machinery Guards Removed. (TM 55-1945-205-24-3-1)
 Drive Train Marine Gear To Transfer Case Machinery Guards Removed. (TM 55-1945-205-24-3-1)
 Drive Train Drive Shafts Removed. (TM 55-1945-205-24-3-1)
 Transfer Case Removed. (WP 0014 00)

PREPARE TRANSFER CASE FOR STORAGE OR SHIPMENT

1. Drain lubricant from transfer case (1).

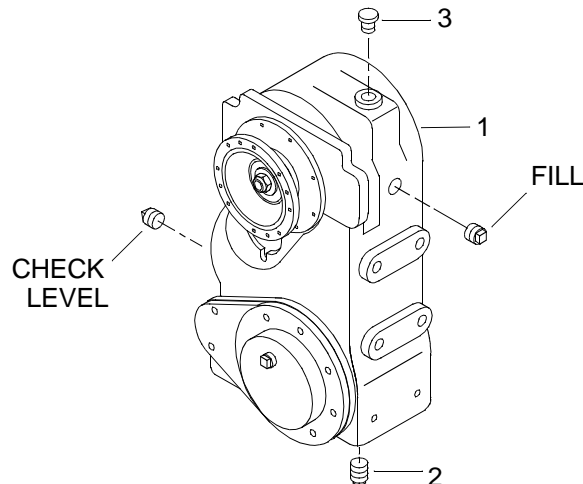

-
- a. Place drain pan under drain plug (2).
 - b. Loosen breather (3).

WARNING



CHEMICAL



EYE PROTECTION

- c. Remove drain plug (2).

WARNING



CHEMICAL

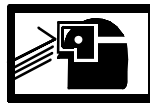

EYE PROTECTION

- d. Drain waste oil in drain pan.
- e. Install drain plug (2).
- f. Tighten breather (3).

WARNING



CHEMICAL

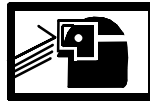

EYE PROTECTION

2. Fill transfer case (1) with lubricating oil to the top prior to storage or shipment.

WARNING



CHEMICAL

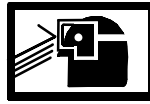

EYE PROTECTION

3. Remove drain pan and dispose of contents in accordance with local procedures.

WARNING

**CHEMICAL****EAR PROTECTION****SLICK FLOOR**

4. Clean up spilled fluid with a spill kit and dispose of spill kit waste in accordance with local procedures.
5. Install a red tag with the instructions: **PRIOR TO OPERATION, DRAIN TRANSFER CASE TO CORRECT OPERATING LEVEL AND SAMPLE THE OIL.**
6. Tie a plastic bag over transfer case breather (3).
7. Install a yellow tag with the instructions: **REMOVE PLASTIC BAG PRIOR TO OPERATION.**

WARNING

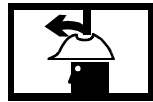
**HEAVY PARTS****HELMET PROTECTION****HEAVY OBJECTS**

8. Using engine and transmission sling, pack transfer case (1) in shipping container.

END OF WORK PACKAGE

UNIT, DIRECT SUPPORT AND GENERAL SUPPORT MAINTENANCE
WARPING TUG
TRANSFER CASE
TORQUE LIMITS

INTRODUCTION

When To Use Torque Limits

When a torque is not specified in an individual work package, use the procedures in this work package to determine proper torque limits and use of adapters with torque wrenches.

How To Use Adapters With Torque Wrenches

When an adaptor is necessary due to space or type of fitting being torqued, it must be determined how the adaptor changes the amount of force applied. If the adaptor increases or decreases the distance from the drive of the torque wrench to the fitting being torqued, an equation must be used to compensate for the difference.

NOTE

The following abbreviations apply to the below procedures:

DT = Desired Torque

LT = Length of Torque Wrench

AL = Adaptor Length

AT = Applied Torque

1. If the adaptor used decreases the distance between the center of the torque wrench handle and the center of the drive, first find the desired torque for the fitting, then calculate as follows:

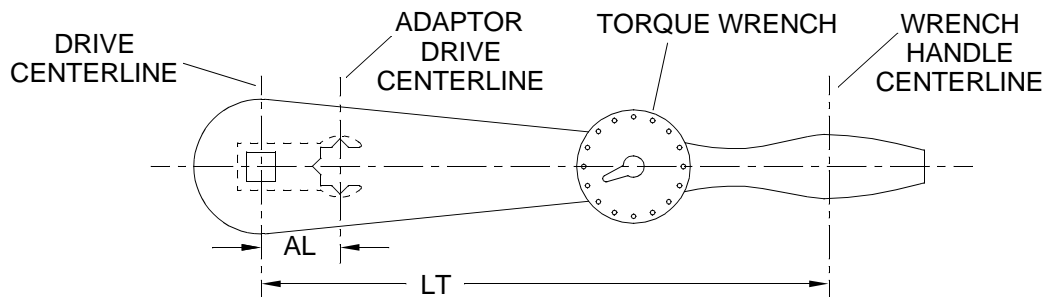

- a. Multiply DT by LT.
 - b. Subtract AL from LT.
 - c. Divide the first answer by the second answer to find AT.
2. If the adaptor used increases the distance between the center of the torque wrench handle and the center of the drive, first find the desired torque for the fitting, then calculate as follows:

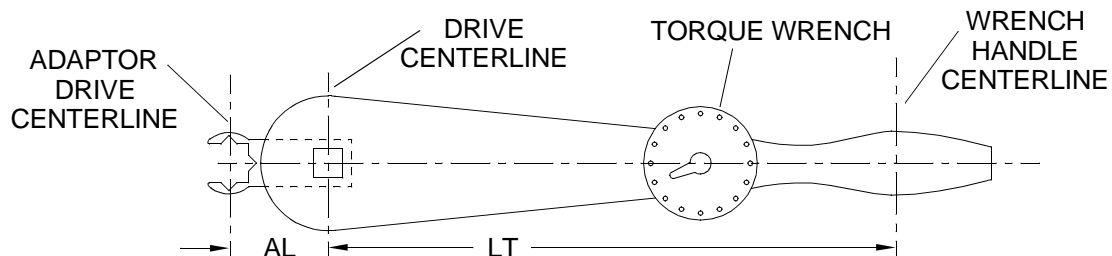

- a. Multiply DT by LT.
- b. Add AL and LT.
- c. Divide the first answer by the second answer to find AT.

TORQUE TABLES

How To Use Torque Tables

1. Measure the diameter of the bolt to be torqued.

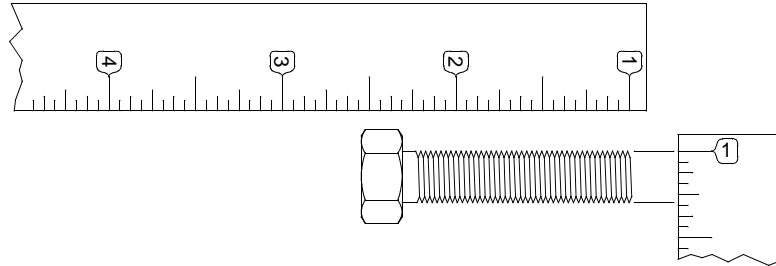

2. For SAE fasteners, determine the threads per inch by counting the threads. For metric fasteners, determine the thread pitch using a thread pitch gage.
3. Determine the type of markings on the bolt you are torquing by comparing the markings on the head of the bolt with the chart below.

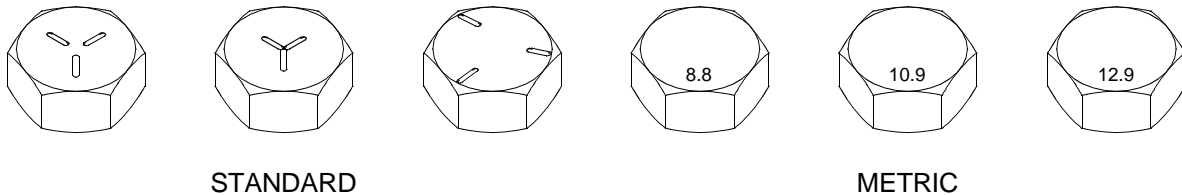

4. Determine if this will be a wet or dry torque.
 - a. Wet torque is any bolt that is lubricated or coated with an antiseize compound.
 - b. Dry torque is any bolt that is not lubricated or coated with an antiseize compound.
5. On the table below, locate the bolt to be torqued.
 - a. Locate the diameter of the bolt.
 - b. Determine the threads per inch for the SAE fastener or the thread pitch for the metric fastener.
 - c. Slide across the table to the proper grade.
 - d. Choose wet or dry.
 - e. Slide down the proper column and across the proper row until they intersect, this is the proper torque value.

Table 1. SAE Standard Torque Table.

		SAE GRADE NO. 2				SAE GRADE NO. 5				SAE GRADE NO. 8			
													
		DRY		WET		DRY		WET		DRY		WET	
DIA IN.	THREADS PER INCH	IN. LBS	N-m	IN. LBS	N-m	IN. LBS	N-m	IN. LBS	N-m	IN. LBS	N-m	IN. LBS	N-m
1/4	20	66	7.46	49	5.54	101	11.41	76	8.58	143	16.15	107	12.09
1/4	28	75	8.47	56	6.33	116	13.10	87	9.83	164	18.53	123	13.89
5/16	18	135	15.25	101	11.41	209	23.61	157	17.73	295	33.32	221	24.96
5/16	24	150	17.17	112	12.65	230	25.98	173	19.54	327	36.94	245	27.68
3/8	16	240	27.11	180	20.33	370	41.80	278	31.40	523	59.08	392	44.28
3/8	24	272	30.73	204	23.04	420	47.44	315	35.58	593	66.99	445	50.27
7/16	14	384	43.38	288	32.53	593	66.99	445	50.27	837	94.55	628	70.94
7/16	20	428	48.35	321	36.26	662	74.78	496	56.03	935	105.62	700	79.07
1/2	13	585	66.08	439	49.59	904	102.12	678	76.59	1277	144.25	958	108.22
1/2	20	660	74.55	495	55.92	1020	115.22	764	86.30	1440	162.66	1080	122.00

Table 2. SAE Standard Torque Table.

		SAE GRADE NO. 2				SAE GRADE NO. 5				SAE GRADE NO. 8			
													
		DRY		WET		DRY		WET		DRY		WET	
DIA IN.	THREADS PER INCH	FT LBS	N-m	FT LBS	N-m	FT LBS	N-m	FT LBS	N-m	FT LBS	N-m	FT LBS	N-m
9/16	12	70	94.92	53	71.87	109	147.80	82	111.19	154	208.82	115	155.94
9/16	18	78	105.77	59	80.00	121	164.08	91	123.40	171	231.88	128	173.57
5/8	11	97	131.53	73	98.99	150	203.40	113	153.23	212	287.47	159	215.60
5/8	18	110	149.16	82	111.19	170	230.52	127	172.21	240	325.44	180	244.08
3/4	10	172	233.23	129	174.92	269	364.76	201	272.56	376	509.86	282	382.39
3/4	16	192	260.35	144	195.26	297	402.73	223	302.29	420	569.52	315	427.14
1	8	-	-	-	-	644	873.26	483	654.95	909	1232.60	683	926.15
1	12	-	-	-	-	704	954.62	528	715.97	995	1349.22	746	1011.58

Table 3. Metric Standard Torque Table.

DIA MM	THREAD PITCH	CLASS 4.6				CLASS 4.8				CLASS 5.8			
		DRY		WET		DRY		WET		DRY		WET	
		N-m	IN. LBS	N-m	IN. LBS	N-m	IN. LBS	N-m	IN. LBS	N-m	IN. LBS	N-m	IN. LBS
3.0	0.5	.50	4	.40	4	.70	6	.50	4	-	-	-	-
3.5	0.6	.80	7	.60	5	1.10	10	.80	7	-	-	-	-
4.0	0.7	1.20	11	.90	8	1.60	14	1.20	11	-	-	-	-
5.0	0.8	2.40	21	1.80	16	3.30	29	2.50	22	4.00	35	3.00	27
6.0	1.0	4.00	35	3.00	27	5.66	50	4.20	37	6.90	61	5.20	26
8.0	1.25	9.90	88	7.40	66	13.60	120	10.20	90	16.70	148	12.50	111
10.0	1.50	19.60	174	14.70	130	27.00	239	20.00	177	33.10	293	24.80	220
12.0	1.75	34.10	302	25.60	227	47.00	416	35.00	310	58.00	51	43.00	381
14.0	2.0	54.30	481	40.80	361	75.00	664	56.00	496	92.00	814	69.00	611

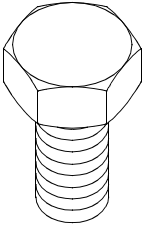
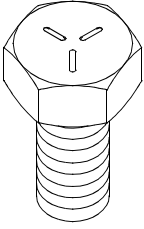
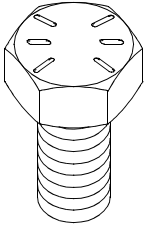
Table 4. Metric Standard Torque Table.

		CLASS 8.8				CLASS 9.8				CLASS 10.9			
													
		DRY		WET		DRY		WET		DRY		WET	
DIA MM	THREAD PITCH	N-m	FT LBS	N-m	FT LBS	N-m	FT LBS	N-m	FT LBS	N-m	FT LBS	N-m	FT LBS
8.0	1.25	26.40	19	19.80	15	28.50	21	21.40	16	36.50	27	27.30	20
10.0	1.50	52.20	38	39.20	29	56.60	42	42.40	31	72.20	53	54.20	40
12.0	1.75	91.00	67	68.00	50	99.00	73	74.00	55	126.00	93	94.00	69
14.0	2.00	145.00	107	109.00	80	157.00	116	118.00	87	200.00	147	150.00	111
16.0	2.00	226.00	167	170.00	125	245.00	181	184.00	136	313.00	231	235.00	173
20.0	2.50	441.00	325	331.00	244	478.00	353	358.00	264	610.00	450	458.00	338
24.0	3.00	762.00	562	572.00	422	826.00	609	620.00	457	1055.00	778	791.00	583
30.0	3.50	1515.00	1117	1136.00	838	1641.00	1210	1231.00	908	2095.00	1545	1572.00	1159
36.0	4.00	2647.00	1952	1985.00	1464	2868.00	2115	2151.00	1586	3662.00	2701	2746.00	2025

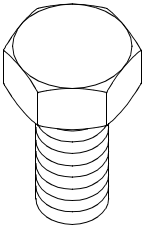
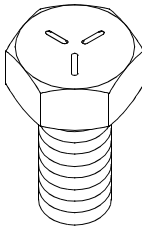
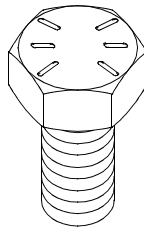
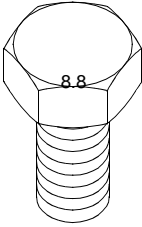
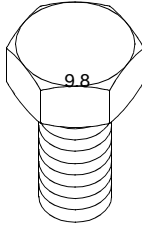
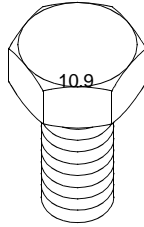
END OF WORK PACKAGE

CHAPTER 4

UNIT, DIRECT SUPPORT AND GENERAL SUPPORT
SUPPORTING INFORMATION
FOR
MODULAR CAUSEWAY SYSTEM (MCS)
WARPING TUG (WT) TRANSFER CASE

**UNIT, DIRECT SUPPORT AND GENERAL SUPPORT MAINTENANCE
WARPING TUG
TRANSFER CASE
REFERENCES**

SCOPE

This work package lists all field manuals, forms, technical manuals and miscellaneous publications referenced in this manual.

ARMY REGULATIONS

AR 700-138 Army Logistics Readiness and Sustainability

DA PAMPHLETS

DA PAM 738-750 Functional Users Manual for The Army Maintenance Management Systems (TAMMS)

FIELD MANUALS

FM 3-5 NBC, Decontamination

FM 55-502 Army Watercraft Safety

FORMS

DA Form 2028 Recommended Changes to Publications and Blank Forms

DA Form 2404 Equipment Inspection and Maintenance Worksheet

SF 368 Product Quality Deficiency Report

MISCELLANEOUS

ASME Y14.38-1999 The American Society of Mechanical Engineers Abbreviations and Acronyms

CTA 8-100 Common Table of Allowances, Army Medical Department Expendable/
Durable Items

CTA 50-970 Common Table of Allowances, Expendable/Durable Items (Except Medical, Class V
Repair Parts, and Heraldic Items)

SUPPLY CATALOGS

SC 4910-95-A68 Shop Equipment, Automotive Equipment and Repair, Field Maintenance

SC 4910-95-A72 Shop Equipment, Automotive Equipment and Repair, Organizational Maintenance

SC 5180-90-N26 Tool Kit, General Mechanic's

SC 5180-90-N55 Sets, Kits and Outfits for Tool Kit, General Mechanic's, Diesel Engine

TECHNICAL MANUALS

■	TM 5-2815-258-10	Operators Manual for Detroit Diesel Engine Series 53
	TM 11-5820-890-10-8	SINGGARS Operators Manual
■	TM 11-5825-291-13	Operations and Maintenance Manual, Satellite Signals Navigations Sets
	TM 55-1945-205-10-3	Operators Maintenance Manual for Warring Tug
	TM 55-1945-205-24-3-1	Unit, Direct Support and General Maintenance, Warring Tug
	TM 55-1945-205-24P-3	Unit, Direct Support and General Support Maintenance, Repair Parts and Special Tools List, Warring Tug
	TM 750-244-6	Destruction of TACOM Equipment

**UNIT, DIRECT SUPPORT AND GENERAL SUPPORT MAINTENANCE
WARPING TUG
MAINTENANCE ALLOCATION CHART (MAC)**

INTRODUCTION

The Army Maintenance System MAC

This introduction provides a general explanation of all maintenance and repair functions authorized at various levels under the standard Army Maintenance System concept.

The MAC (immediately following the introduction) designates overall authority and responsibility for the performance of maintenance functions on the identified end item or component. The application of the maintenance functions to the end item or component shall be consistent with the capacities of the designated maintenance levels, which are shown on the MAC in column (4) as:

Unit - includes O (unit) maintenance.

Direct Support - includes an F subcolumn.

General Support - includes an H subcolumn.

Depot - includes a D subcolumn.

The tools and test equipment requirements, immediately following the MAC, if applicable, list the tools and test equipment, both special tools and common tool sets, required for each maintenance function as referenced from the MAC.

The remarks, immediately following the tools and test equipment requirements, if applicable, contain supplemental instructions and explanatory notes for a particular maintenance function.

Maintenance Functions

Maintenance functions are limited to and defined as follows:

1. Inspect. To determine the serviceability of an item by comparing its physical, mechanical and/or electrical characteristics with established standards through examination, e.g., by sight, sound or feel. This includes scheduled inspection and gaugings and evaluation of cannon tubes.
2. Test. To verify serviceability by measuring the mechanical, pneumatic, hydraulic or electrical characteristics of an item and comparing those characteristics with prescribed standards on a scheduled basis, i.e., load testing of lift devices and hydrostatic testing of pressure hoses.
3. Service. Operations required periodically to keep an item in proper operating conditions; e.g., to clean, includes decontaminate, when required, to preserve, to drain, to paint or to replenish fuel, lubricants, chemical fluids or gases. This includes scheduled exercising and purging of recoil mechanisms.
4. Adjust. To maintain or regulate, within prescribed limits, by bringing into proper position, or by setting the operating characteristics to specified parameters.
5. Align. To adjust specified variable elements of an item to bring about optimum or desired performance.

6. Calibrate. To determine and cause corrections to be made or to be adjusted on instruments or test, measuring and diagnostic equipment used in precision measurement. Consists of comparisons of two instruments, one of which is a certified standard of known accuracy, to detect and adjust any discrepancy in the accuracy of the instrument being compared.
7. Remove/Install. To remove and install the same item when required to perform service or other maintenance functions. Install may be the act of emplacing, seating or fixing into position a spare, repair part or module (component or assembly) in a manner to allow the proper functioning of an equipment or system.
8. Replace. To remove an unserviceable item and install a serviceable counterpart in its place. "Replace" is authorized by the MAC and assigned maintenance level is shown as the third position code of the Source, Maintenance and Recoverability (SMR) code.
9. Repair. The application of the maintenance services, including fault location/troubleshooting, removal/installation, disassembly/assembly procedures and maintenance actions to identify troubles and restore serviceability to an item by correcting specific damage, fault, malfunction or failure in a part, subassembly, module (component or assembly), end item or system.

NOTE

The following definitions are applicable to the "repair" maintenance function:

Services - inspect, test, service, adjust, align, calibrate and/or replace.

Fault location/troubleshooting - the process of investigating and detecting the cause of equipment malfunctioning; the act of isolating a fault within a system or Unit Under Test (UUT).

Disassembly/assembly - the step-by-step breakdown (taking apart) of a spare/functional group coded item to the level of its least component, that is assigned an SMR code for the level of maintenance under consideration (i.e., identified as maintenance significant).

Actions - welding, grinding, riveting, straightening, facing, machining and/or resurfacing.

10. Overhaul. That maintenance effort (service/action) prescribed to restore an item to a completely serviceable/operational condition as required by maintenance standards in appropriate technical publications. Overhaul is normally the highest degree of maintenance performed by the Army. Overhaul does not normally return an item to like new condition.
11. Rebuild. Consists of those services/actions necessary for the restoration of unserviceable equipment to a like new condition in accordance with original manufacturing standards. Rebuild is the highest degree of maintenance applied to Army equipment. The rebuild operation includes the act of returning to zero those age measurements (e.g., hours/miles) considered in classifying Army equipment/components.

Explanation of Columns in the MAC

Column (1) - Group Number. Column (1) lists FGC numbers, the purpose of which is to identify maintenance significant components, assemblies, subassemblies, and modules with the Next Higher Assembly (NHA).

Column (2) - Component/Assembly. Column (2) contains the item names of components, assemblies, subassemblies and modules for which maintenance is authorized.

Column (3) - Maintenance Function. Column (3) lists the functions to be performed on the item listed in column (2). For a detailed explanation of these functions refer to "Maintenance Functions" outlined above.

Column (4) - Maintenance Level. Column (4) specifies each level of maintenance authorized to perform each function listed in column (3), by indicating work time required (expressed as man-hours in whole hours or decimals) in the appropriate subcolumn. This work time figure represents the active time required to perform that maintenance function at the indicated level of maintenance. If the number or complexity of the tasks within the listed maintenance function varies at different maintenance levels, appropriate work time figures are to be shown for each level. The work time figures represent the average time required to restore an item (assembly, subassembly, component, module, end item or system) to a serviceable condition under typical field operating conditions. This time includes preparation time (including any necessary disassembly/assembly time), troubleshooting/fault location time, and quality assurance time in addition to the time required to perform the specific tasks identified for the maintenance functions authorized in the MAC. The symbol designations for the various maintenance levels are as follows:

NOTE

The "L" maintenance level is not included in column (4) of the MAC. Functions to this level of maintenance are identified by a work time figure in the "H" column of column (4) and an associated reference code is used in the remarks column (6). This code is keyed to the remarks and the SRA complete repair application is explained there.

O - Unit maintenance

F - Direct support maintenance

L - Specialized Repair Activity (SRA)

H - General support maintenance

D - Depot maintenance

Column (5) - Tools and Equipment Reference Code. Column (5) specifies, by code, those common tool sets (not individual tools), common Test, Measurement and Diagnostic Equipment (TMDE), and special tools, special TMDE and special support equipment required to perform the designated function. Codes are keyed to the entries in the tools and test equipment table.

Column (6) - Remarks Code. When applicable, this column contains a letter code, in alphabetical order, which is keyed to the remarks table entries.

Explanation of Columns in the Tools and Test Equipment Requirements

Column (1) - Tool or Test Equipment Reference Code. The tool or test equipment reference code correlates with a code used in column (5) of the MAC.

Column (2) - Maintenance Level. The lowest level of maintenance authorized to use the tool or test equipment.

Column (3) - Nomenclature. Name or identification of the tool or test equipment.

Column (4) - National Stock Number (NSN). The NSN of the tool or test equipment.

Column (5) - Tool Number. The manufacturer's part number, model number or type number.

Explanation of Columns in the Remarks

Column (1) - Remarks Code. The code recorded in column (6) of the MAC.

Column (2) - Remarks. This column lists information pertinent to the maintenance function being performed as indicated in the MAC.

**UNIT, DIRECT SUPPORT AND GENERAL SUPPORT MAINTENANCE
WARPING TUG TRANSFER CASE
MAINTENANCE ALLOCATION CHART**

MAINTENANCE ALLOCATION CHART

Table 1. MAC for Modular Causeway System. (MCS)

(1) GROUP NO.	(2) COMPONENT/ASSEMBLY	(3) MAINTENANCE FUNCTION	(4) MAINTENANCE LEVEL				(5) TOOLS AND EQUIP REF CODE	(6) REMARKS CODE	
			UNIT		DS	GS			DEPOT
			C	O	F	H			D
00	MODULAR CAUSEWAY SYSTEM (MCS)								
01	CAUSEWAY FERRY (CF)								
0101	POWERED SECTION								
010101	POWERED MODULE								
01010101	DRIVE TRAIN								
0101010101	DIESEL ENGINE							A	
0101010102	MARINE GEAR							B	
0101010103	TRANSFER CASE							C	
0101010104	PUMP-JET	Inspect	0.5					E	
		Service		3.0			1	E	
		Repair				10.0		D	
		Replace				50.0		D	
010101010401	HYDRAULIC SYSTEM	Inspect	1.0					E	
		Service	1.0	3.0			1	E	
		Repair			3.0		2, 4, 7		
		Replace			6.0		2, 4, 7		
01010101040101	HYDRAULIC PUMP	Test	0.5					E	
		Inspect	1.0					E	

Table 1. MAC for Modular Causeway System. (MCS) (Continued)

(1) GROUP NO.	(2) COMPONENT/ASSEMBLY	(3) MAINTENANCE FUNCTION	(4) MAINTENANCE LEVEL					(5) TOOLS AND EQUIP REF CODE	(6) REMARKS CODE
			UNIT		DS	GS	DEPOT		
			C	O	F	H	D		
01010101040101	HYDRAULIC PUMP (CONT'D)	Repair				4.0		2, 4, 7	E
		Replace		6.0				1, 2, 4	
01010101040102	HYDRAULIC HAND PUMP	Inspect	1.0						E
		Repair					20.0		
		Replace		2.0				1, 2, 4	
01010101040103	HYDRAULIC WAY-VALVE	Repair				2.0		2, 4, 7	
		Replace		1.5				1, 2, 4	
010101010403	FEEDBACK UNIT	Inspect	1.0						E
		Repair				2.5		2, 4, 7	
		Replace			2.0			2, 4, 7	
0101010105	ALTERNATOR	Test			1.0			7, 14, 15	E
		Inspect	0.5						E
		Replace			2.0			7, 14, 15	
01010102	ENGINE EXHAUST SYSTEM	Clean		2.0				1, 3, 9	E
		Inspect		2.0				1, 3, 9	E
		Repair			6.0			3, 7, 9	
01010103	BILGE PUMP	Test		2.0				1	E
		Inspect	1.0						E
		Replace		8.0				1	F
01010104	FIRE SUPPRESSION SYSTEM	Test					3.0		E
		Inspect	2.0				3.0		E
		Repair					8.0		G
		Replace					24.0		G

Table 1. MAC for Modular Causeway System. (MCS) (Continued)

(1) GROUP NO.	(2) COMPONENT/ASSEMBLY	(3) MAINTENANCE FUNCTION	(4) MAINTENANCE LEVEL					(5) TOOLS AND EQUIP REF CODE	(6) REMARKS CODE
			UNIT		DS	GS	DEPOT		
			C	O	F	H	D		
01010105	FUEL SYSTEM	Test	1.0						E
		Inspect	1.0						E
		Repair			4.0			7	
		Replace			12.0			7	
0101010501	FUEL/WATER SEPARATOR	Clean	1.0						E
		Inspect	1.0						E
		Repair		2.0				1	
		Replace			4.0			7	
01010106	ELECTRICAL SYSTEM	Test			1.0			7, 14, 15	E
		Adjust			1.0			7, 14, 15	
		Repair			2.0			7, 14, 15	
		Replace			8.0			7, 14, 15	
01010107	EMERGENCY STEERING SYSTEM	Inspect	2.0						E
		Service	1.0						E
		Replace		4.0				1	
0101010701	STEERING UNIT	Inspect	0.5						E
		Replace		2.0				1, 2	
0101010702	STEERING ADAPTOR	Inspect	0.5						E
		Replace		1.5				1	
01010108	HULL								
0101010801	EXTERIOR	Clean		4.0				8, 9, 23, 24	E
		Inspect	1.0						E
		Service	1.5						E

Table 1. MAC for Modular Causeway System. (MCS) (Continued)

(1) GROUP NO.	(2) COMPONENT/ASSEMBLY	(3) MAINTENANCE FUNCTION	(4) MAINTENANCE LEVEL				(5) TOOLS AND EQUIP REF CODE	(6) REMARKS CODE	
			UNIT		DS	GS			DEPOT
			C	O	F	H			D
0101010801	EXTERIOR (CONT'D)	Repair		4.0				1, 16	
		Overhaul					24.0		
0101010802	INTERIOR	Clean					4.0		
		Inspect					2.0		
		Test		8.0			5.0	1, 25, 26	E
		Repair					6.0		
		Overhaul					50.0		
01010109	GUILLOTINE FITTINGS	Clean		1.0				8, 9, 23, 24	E
		Inspect	0.5						E
		Repair		3.0				1, 16	
		Replace		1.0				1	
01010110	HATCHES & HINGES	Clean	1.0					8, 9, 23, 24	E
		Inspect	0.5						E
		Service	0.5						E
		Repair		2.0				1, 16	
		Replace		2.0				1	
0101010111	FLEXORS	Inspect	0.5						E
		Replace	4.0						
010102	NON-POWERED MODULES								
01010201	HULL								
0101020101	EXTERIOR	Clean		4.0				8, 9, 23, 24	E
		Inspect	1.0						E
		Service	1.5						E

Table 1. MAC for Modular Causeway System. (MCS) (Continued)

(1) GROUP NO.	(2) COMPONENT/ASSEMBLY	(3) MAINTENANCE FUNCTION	(4) MAINTENANCE LEVEL					(5) TOOLS AND EQUIP REF CODE	(6) REMARKS CODE
			UNIT		DS	GS	DEPOT		
			C	O	F	H	D		
0101020101	EXTERIOR (CONT'D)	Repair		4.0				1, 16	
		Overhaul					24.0		
0101020102	INTERIOR	Clean					4.0		
		Inspect					2.0		
		Test					5.0	1, 25, 26	E
		Repair					6.0		
		Overhaul					50.0		
01010202	GUILLOTINE FITTINGS	Clean		1.0				8, 9, 23, 24	E
		Inspect	0.5						E
		Repair		3.0				1, 16	
		Replace		1.0				1	
01010203	FLEXORS	Inspect	0.5						E
		Replace	4.0						
010103	OPERATORS CAB								
01010301	MIDDLE CONTROL PANEL	Test			2.0			7, 14, 15	E
		Inspect			2.0			7, 14, 15	E
		Repair			3.0			7, 14, 15	
		Replace			16.0			7, 14, 15	
01010302	LOWER CONTROL PANEL	Test			2.0			7, 14, 15	E
		Inspect			2.0			7, 14, 15	E
		Repair			3.0			7, 14, 15	
		Replace			16.0			7, 14, 15	

Table 1. MAC for Modular Causeway System. (MCS) (Continued)

(1) GROUP NO.	(2) COMPONENT/ASSEMBLY	(3) MAINTENANCE FUNCTION	(4) MAINTENANCE LEVEL					(5) TOOLS AND EQUIP REF CODE	(6) REMARKS CODE
			UNIT		DS	GS	DEPOT		
			C	O	F	H	D		
01010303	CIRCUIT BREAKER PANEL	Test			1.0			7, 14, 15	E
		Inspect			1.0			7, 14, 15	E
		Repair			2.0			7, 14, 15	
		Replace			12.0			7, 14, 15	
01010304	TERMINAL STRIP A-4	Test			1.0			7, 14, 15	E
		Inspect			1.0			7, 14, 15	E
		Repair			2.0			7, 14, 15	
		Replace			10.0			7, 14, 15	
01010305	SPOTLIGHT	Adjust		1.0				1	
		Replace		1.0				1	
01010306	DEFROSTER	Inspect	1.0						E
		Replace			4.0			7, 14, 15	
01010307	HEATER	Inspect		2.0				1	
		Repair			4.0			7, 14, 15	
		Replace			6.0			7, 14, 15	
01010308	WINDSHIELD WIPER	Repair		1.0				1	
		Replace		2.0				1	
01010309	COMMUNICATIONS EQUIPMENT								
0101030901	VHF/FM HANDHELD TRANSCEIVER	Repair					8.0		
		Replace		1.0				1	

Table 1. MAC for Modular Causeway System. (MCS) (Continued)

(1) GROUP NO.	(2) COMPONENT/ASSEMBLY	(3) MAINTENANCE FUNCTION	(4) MAINTENANCE LEVEL					(5) TOOLS AND EQUIP REF CODE	(6) REMARKS CODE
			UNIT		DS	GS	DEPOT		
			C	O	F	H	D		
0101030902	AN/PSN-11 INTERFACE & SWITCHBOX	Repair					6.0		
		Replace			1.0			7, 14, 15	
0101030903	LOUDHAILER	Repair					8.0		
		Replace	0.5						
0101030904	SINGGARS RADIO								H
0101030905	VHF/FM DCS TRANSCEIVER	Repair					12.0		
		Replace		1.0				1	
01010310	NAVIGATION EQUIPMENT	Test	0.5						E
		Inspect		1.0					E
0101031001	COMPASS	Inspect	2.0.						E
		Replace		2.0				1	
		Calibrate		4.0				1	E
0101031002	PLGR								I
01010311	MAST	Inspect	3.0						E
		Repair		3.0				1	
0101031101	NAVIGATION LIGHTS	Repair		1.0				1	
		Replace		1.0				1	
0101312	OPERATORS CAB ELECTRICAL SYSTEM	Test			4.0			7, 14, 15	E
		Inspect			4.0			7, 14, 15	E
		Repair				6.0		7, 14, 15	
		Replace			10.0			7, 14, 15	

Table 1. MAC for Modular Causeway System. (MCS) (Continued)

(1) GROUP NO.	(2) COMPONENT/ASSEMBLY	(3) MAINTENANCE FUNCTION	(4) MAINTENANCE LEVEL					(5) TOOLS AND EQUIP REF CODE	(6) REMARKS CODE
			UNIT		DS	GS	DEPOT		
			C	O	F	H	D		
010104	ANCHOR ASSEMBLY	Inspect	1.0						E
		Repair		1.0				1	
		Replace		1.0				1	
0102	INTERMEDIATE SECTION								
010201	NON-POWERED MODULES								
01020101	HULL								
0102010101	EXTERIOR	Clean		4.0				8, 9, 23, 24	E
		Inspect	1.0						E
		Service	1.5						E
		Repair		4.0				1, 16	
		Overhaul					24.0		
0102010102	INTERIOR	Clean					4.0		
		Inspect					2.0		
		Test		8.0			5.0	1, 25, 26	E
		Repair					6.0		
		Overhaul					50.0		
01020102	GUILLOTINE FITTINGS	Clean		1.0				8, 9, 23, 24	E
		Inspect	0.5						E
		Repair		3.0				1, 16	
		Replace		1.0				1	
01020103	FLEXORS	Inspect	0.5						E
		Replace	4.0						

Table 1. MAC for Modular Causeway System. (MCS) (Continued)

(1) GROUP NO.	(2) COMPONENT/ASSEMBLY	(3) MAINTENANCE FUNCTION	(4) MAINTENANCE LEVEL				(5) TOOLS AND EQUIP REF CODE	(6) REMARKS CODE	
			UNIT		DS	GS			DEPOT
			C	O	F	H			D
0103	CAUSEWAY FERRY BEACH- END SECTION								
010301	NON-POWERED MODULE								
01030101	HULL								
0103010101	EXTERIOR	Clean		4.0				8, 9, 23, 24	E
		Inspect	1.0						E
		Service	1.5						E
		Repair		4.0				1, 16	
		Overhaul					24.0		
0103010102	INTERIOR	Clean					4.0		
		Inspect					2.0		
		Test		8.0			5.0	1, 25, 26	E
		Repair					6.0		
		Overhaul					50.0		
01030102	GUILLOTINE FITTINGS	Clean		1.0				8, 9, 23, 24	E
		Inspect	0.5						E
		Repair		3.0				1, 16	
		Replace		1.0				1	
01030103	FLEXORS	Inspect	0.5						E
		Replace	4.0						
0104	CONTAINERS	Clean	1.0						E
		Inspect	2.0						E
		Repair			4.0			7	
		Replace					8.0		

Table 1. MAC for Modular Causeway System. (MCS) (Continued)

(1) GROUP NO.	(2) COMPONENT/ASSEMBLY	(3) MAINTENANCE FUNCTION	(4) MAINTENANCE LEVEL					(5) TOOLS AND EQUIP REF CODE	(6) REMARKS CODE
			UNIT		DS	GS	DEPOT		
			C	O	F	H	D		

Table 1. MAC for Modular Causeway System. (MCS) (Continued)

(1) GROUP NO.	(2) COMPONENT/ASSEMBLY	(3) MAINTENANCE FUNCTION	(4) MAINTENANCE LEVEL					(5) TOOLS AND EQUIP REF CODE	(6) REMARKS CODE
			UNIT		DS	GS	DEPOT		
			C	O	F	H	D		
00	MODULAR CAUSEWAY SYSTEM (MCS)								
01	CAUSEWAY FERRY (CF)								
0101010101	DIESEL ENGINE	Inspect	4.0					E	
		Service	4.0	4.0				E	
		Repair				30.0		7, 27-218	
		Replace			120.0			7, 27-218	
		Overhaul					80.0		
010101010101	ENGINE BLOCK ASSEMBLY	Inspect	2.0					E, J	
		Repair				6.0		7, 27-52 J	
		Replace				120.0		7, 27-52 J	
010101010102	CYLINDER HEAD ASSEMBLY	Clean				5.0		7, 53-85 E, K	
		Repair				12.0		7, 53-85 K	
		Inspect			6.0			7, 53-85 E, K	
		Replace			8.0			7, 53-85 K	
010101010103	CRANKSHAFT ASSEMBLY	Repair			16.0			7, 86-106 L	
		Replace			24.0			7, 86-106 L	
010101010104	CAMSHAFT ASSEMBLY	Repair				12.0		7, 131-141	
		Replace				16.0		7, 131-141	
010101010105	FLYWHEEL ASSEMBLY	Inspect			3.0			7, 107-112 M	
		Replace			5.0			7, 107-112 M	

Table 1. MAC for Modular Causeway System. (MCS) (Continued)

(1) GROUP NO.	(2) COMPONENT/ASSEMBLY	(3) MAINTENANCE FUNCTION	(4) MAINTENANCE LEVEL					(5) TOOLS AND EQUIP REF CODE	(6) REMARKS CODE	
			UNIT		DS	GS	DEPOT			
			C	O	F	H	D			
010101010106	PISTON ASSEMBLY	Clean				2.0		7, 113-130	N	
		Repair				3.0		7, 107-112	M	
		Inspect				2.0		7, 113-130	N	
		Rebuild				4.5		7, 113-130	N	
		Replace				3.0		7, 113-130	N	
010101010107	ENGINE BALANCE	Inspect				6.0		7, 131-141	O	
		Adjust				3.0		7, 131-141	O	
		Replace				8.0		7, 131-141	O	
		Repair				8.0		7, 131-141	O	
010101010108	FUEL SYSTEM	Inspect	0.5						E, P	
01010101010801	FUEL PUMP	Inspect				1.0		7, 142-187	E	
		Repair				4.0		7, 142-187		
		Replace				2.0		7, 142-187		
01010101010802	PRIMING PUMP	Inspect		1.5				1, 142-187	E	
		Replace		2.0				1, 142-187		
010101010109	ELECTRIC GOVERNOR	Test				0.5				E
		Adjust		1.0				7, 142-187		
		Repair					5.0			
		Replace		2.0				1, 142-187		
010101010110	AIR INTAKE SYSTEM	Inspect	0.5							E, Q
		Clean		2.0				1, 188-195	E, Q	
		Replace		3.0				1, 188-195	Q	

Table 1. MAC for Modular Causeway System. (MCS) (Continued)

(1) GROUP NO.	(2) COMPONENT/ASSEMBLY	(3) MAINTENANCE FUNCTION	(4) MAINTENANCE LEVEL					(5) TOOLS AND EQUIP REF CODE	(6) REMARKS CODE
			UNIT		DS	GS	DEPOT		
			C	O	F	H	D		
01010101011001	BLOWER	Inspect			2.0	2.0		7, 188-195	E
		Adjust				4.0		7, 188-195	
		Repair				18.0		7, 188-195	
01010101011002	TURBOCHARGER	Inspect		2.0				1, 188-195	E, R
		Replace			8.0			7, 188-195	
		Repair					18.0		
		Replace			6.0			7, 188-195	
010101010111	LUBE OIL SYSTEM	Service	5.0	5.0					E, S
		Inspect	1.0						E
01010101011101	LUBE OIL PUMP	Inspect				3.0		7, 196-203	E
		Repair				4.0		7, 196-203	
		Replace				4.0		7, 196-203	
01010101011102	LUBE OIL COOLER	Clean			2.0			7	E
		Test			1.5			7, 25, 26	E
		Inspect			2.0			7	E
		Repair			4.0			7	E
		Replace			2.0			7	
010101010112	FRESH WATER COOLING SYSTEM	Inspect	1.0						E, T
		Clean		1.0				1	
01010101011201	FRESH WATER PUMP	Inspect			2.5			7, 212-215	E
		Repair			6.0			7, 212-215	
		Replace			3.0			7, 212-215	
		Test			2.0			7, 25, 26	E

Table 1. MAC for Modular Causeway System. (MCS) (Continued)

(1) GROUP NO.	(2) COMPONENT/ASSEMBLY	(3) MAINTENANCE FUNCTION	(4) MAINTENANCE LEVEL					(5) TOOLS AND EQUIP REF CODE	(6) REMARKS CODE
			UNIT		DS	GS	DEPOT		
			C	O	F	H	D		
01010101011202	FRESH WATER COOLER	Clean			2.0			7	E
		Inspect			1.0			7	E
		Repair			4.0			7	
		Replace			3.0			7	
010101010113	RAW WATER COOLING SYSTEM	Inspect	1.0					E, U	
01010101011301	RAW WATER PUMP	Inspect		2.0				1	E
		Clean		2.0				1	E, U
		Repair			4.0			7, 212-215	
		Replace		2.5				1, 212-215	
010101010114	ELECTRICAL SYSTEM	Test			4.0			7, 14, 15	E, V
		Inspect			2.0			7, 14, 15	E, V
		Repair			3.0			7, 14, 15	V
		Replace			16.0			1, 7, 14, 15	V
01010101011401	STARTER	Inspect	1.0						E
		Repair				6.0		7, 14, 15	
		Replace		3.0				1, 14, 15	
01010101011402	COLD PACK STARTER	Clean		1.0				1	E
		Inspect	0.5						E
		Adjust		1.0				1, 14, 15	
		Repair		2.5				1, 14, 15	
		Replace		3.0				1, 14, 15	

Table 1. MAC for Modular Causeway System. (MCS) (Continued)

(1) GROUP NO.	(2) COMPONENT/ASSEMBLY	(3) MAINTENANCE FUNCTION	(4) MAINTENANCE LEVEL					(5) TOOLS AND EQUIP REF CODE	(6) REMARKS CODE
			UNIT		DS	GS	DEPOT		
			C	O	F	H	D		
010101010115	OVER SPEED GOVERNOR	Test				1.0		7	E
		Adjust				1.5		7, 184-187	
		Repair				5.0		7, 184-187	
		Replace				4.0		7, 184-187	
010101010116	AUTO SHUTDOWN SYSTEM	Test		1.0					E
		Adjust			2.0			7, 14, 15	
		Repair				6.0		7, 14, 15	
		Replace		4.0			8.0	1	

Table 1. MAC for Modular Causeway System. (MCS) (Continued)

(1) GROUP NO.	(2) COMPONENT/ASSEMBLY	(3) MAINTENANCE FUNCTION	(4) MAINTENANCE LEVEL					(5) TOOLS AND EQUIP REF CODE	(6) REMARKS CODE
			UNIT		DS	GS	DEPOT		
			C	O	F	H	D		

Table 1. MAC for Modular Causeway System. (MCS) (Continued)

(1) GROUP NO.	(2) COMPONENT/ASSEMBLY	(3) MAINTENANCE FUNCTION	(4) MAINTENANCE LEVEL					(5) TOOLS AND EQUIP REF CODE	(6) REMARKS CODE
			UNIT		DS	GS	DEPOT		
			C	O	F	H	D		
00	MODULAR CAUSEWAY SYSTEM (MCS)								
01	CAUSEWAY FERRY (CF)								
0101010102	MARINE GEAR	Inspect	1.0						E
		Align			2.0			7, 17	
		Service	1.0	4.0				1	E
		Rebuild					25.0		W
		Replace			28.0			4, 7, 17	
010101010201	OIL SYSTEM	Inspect	0.5						E, X
		Repair		.5				1, 11	X
01010101020101	OIL COOLER	Clean	1.0						E
		Inspect	1.0						E
		Replace		4.0				1	
01010101020102	LINES & HOSES	Inspect	0.5						E
		Repair		1.0				1	
01010101020103	OIL PUMP	Inspect	1.0						E
		Repair		2.0				1, 3	
01010101020104	ELECTRIC CONTROL VALVE	Repair					8.0		
		Replace			6.0			7, 14, 15	
010101010202	GEAR MOUNTS	Inspect	.05						E
		Replace			2.0			3,7	
010101010203	COUPLING BLOCKS	Clean			1.0			7	E
		Inspect			1.0			7	E
		Replace			4.0			3, 7	

Table 1. MAC for Modular Causeway System. (MCS) (Continued)

(1) GROUP NO.	(2) COMPONENT/ASSEMBLY	(3) MAINTENANCE FUNCTION	(4) MAINTENANCE LEVEL					(5) TOOLS AND EQUIP REF CODE	(6) REMARKS CODE
			UNIT		DS	GS	DEPOT		
			C	O	F	H	D		
010101010204	OUTPUT FLANGE	Inspect	0.5						E
		Align			2.0			3, 7, 17	
		Replace			4.0			3, 7, 17	
010101010205	OUTPUT SEAL	Inspect			2.0			7	E
		Replace			2.0			3, 7	
010101010206	INPUT FLANGE (ENGINE CONNECTION)	Inspect	0.5						E

Table 1. MAC for Modular Causeway System. (MCS) (Continued)

(1) GROUP NO.	(2) COMPONENT/ASSEMBLY	(3) MAINTENANCE FUNCTION	(4) MAINTENANCE LEVEL					(5) TOOLS AND EQUIP REF CODE	(6) REMARKS CODE
			UNIT		DS	GS	DEPOT		
			C	O	F	H	D		
00	MODULAR CAUSEWAY SYSTEM (MCS)								
01	CAUSEWAY FERRY (CF)								
0101010103	TRANSFER CASE	Clean		2.0				1	E
		Service	1.0	4.0				1	E
		Overhaul				24.0			
		Rebuild					24.0	2, 7, 17	Y
		Replace			24.0			2, 7, 17	
010101010301	OIL SYSTEM	Inspect	1.0						E
		Repair		2.5				1	
01010101030101	OIL PUMP	Inspect	4.0						E
		Replace		2.5				1	
01010101030102	HOSES & FITTINGS	Inspect	0.2						E
		Replace		2.0				1	
01010101030103	OIL COOLER	Inspect	0.2						E
010101010302	GEAR SHAFT	Inspect				5.0		7	E
		Replace		3.5				1	
		Repair				8.0		3, 7, 17	
		Replace				7.0		3, 7, 17, 19	
01010101030201	UPPER SHAFT	Inspect				5.0		7	X E
		Repair				8.0		3, 7, 17	
		Replace				7.0		3, 7, 17, 19	

Table 1. MAC for Modular Causeway System. (MCS) (Continued)

(1) GROUP NO.	(2) COMPONENT/ASSEMBLY	(3) MAINTENANCE FUNCTION	(4) MAINTENANCE LEVEL					(5) TOOLS AND EQUIP REF CODE	(6) REMARKS CODE
			UNIT		DS	GS	DEPOT		
			C	O	F	H	D		
0101010103020101	INPUT SEAL	Clean			2.0			7	E
		Inspect			2.0			7	E
		Replace			2.0			3, 7, 17, 19	
0101010103020102	OUTPUT SEAL	Clean			2.0			7	E
		Inspect			2.0			7	E
		Replace			2.0			3, 7, 17, 19	
01010101030202	INTERMEDIATE SHAFT	Inspect				2.5		7	E
		Repair				5.5		3, 7, 17	
		Replace				6.5		3, 7, 17, 19	
01010101030203	LOWER SHAFT	Inspect				4.0		7	E
		Repair				8.0		3, 7, 17	
		Replace				6.0		3, 7, 17, 19	
0101010103020301	INPUT SEAL	Clean			2.0			7	E
		Replace			2.0			3, 7, 17, 19	
		Inspect			2.0			7	E

Table 1. MAC for Modular Causeway System. (MCS) (Continued)

(1) GROUP NO.	(2) COMPONENT/ASSEMBLY	(3) MAINTENANCE FUNCTION	(4) MAINTENANCE LEVEL					(5) TOOLS AND EQUIP REF CODE	(6) REMARKS CODE
			UNIT		DS	GS	DEPOT		
			C	O	F	H	D		
00	MODULAR CAUSEWAY SYSTEM (MCS)								
01	CAUSEWAY FERRY (CF)								
02	ROLL-ON/ROLL- OFF DISCHARGE FACILITY (RRDF)								
0201	INTERMEDIATE SECTION								
020101	NON-POWERED MODULE								
02010101	HULL								
0201010101	EXTERIOR	Clean		4.0				8, 9, 23, 24	E
		Inspect	1.0						E
		Repair		4.0				1, 16	
		Service	1.5						E
		Overhaul					24.0		
		Inspect					2.0		
0201010102	INTERIOR	Clean					4.0		
		Test		6.0			5.0	1, 25, 26	E
		Repair					6.0		
02010102	GUILLOTINE FITTINGS	Clean		1.0				8, 9, 23, 24	E
		Overhaul					50.0		
		Inspect	0.5						E
		Repair		3.0				1, 16	
		Replace		1.0				1	

Table 1. MAC for Modular Causeway System. (MCS) (Continued)

(1) GROUP NO.	(2) COMPONENT/ASSEMBLY	(3) MAINTENANCE FUNCTION	(4) MAINTENANCE LEVEL					(5) TOOLS AND EQUIP REF CODE	(6) REMARKS CODE
			UNIT		DS	GS	DEPOT		
			C	O	F	H	D		
02010103	FLEXORS	Inspect	0.5						E
		Replace	4.0						
0202	COMBINATION BEACH-END SECTION								
020201	NON-POWERED MODULE								
02020101	HULL								
0202010101	EXTERIOR	Clean		4.0				8, 9, 23, 24	E
		Inspect	1.0						E
		Service	1.5						E
		Repair		4.0				1, 16	
		Overhaul					24.0		
		Inspect					2.0		
0202010102	INTERIOR	Clean					4.0		
		Test		6.0			5.0	1, 25, 26	E
		Repair					6.0		
		Overhaul					50.0		
02020102	GUILLOTINE FITTINGS	Clean		1.0				8, 9, 23, 24	E
		Inspect	0.5						E
		Repair		3.0				1, 16	
		Replace		1.0				1	
02020103	FLEXORS	Inspect	0.5						E
		Replace	4.0						
0203	GENERATOR SHELTER			4.0				1	

Table 1. MAC for Modular Causeway System. (MCS) (Continued)

(1) GROUP NO.	(2) COMPONENT/ASSEMBLY	(3) MAINTENANCE FUNCTION	(4) MAINTENANCE LEVEL					(5) TOOLS AND EQUIP REF CODE	(6) REMARKS CODE
			UNIT		DS	GS	DEPOT		
			C	O	F	H	D		
020301	ARMY TACTICAL QUIET GENERATOR (ATQG)								AD
020302	FUEL SYSTEM	Inspect	1.0						E
		Repair			1.5			7	
		Replace		1.0				1	
02030201	MANUAL FUEL PUMP	Clean		1.0				1	E
		Inspect	1.0	1.0				1	E
		Repair		2.0				1	
		Replace		2.0				1	
020303	LOUVERS	Clean		1.0				1	E
		Inspect	1.0						E
		Service		1.0				1	E
		Repair		3.0				1	
		Replace		4.0				1	
020304	ELECTRICAL SYSTEM	Test			2.0			7, 14, 15	E
		Repair		2.0	3.0			1, 7, 14, 15	
		Replace			5.0			7, 14, 15	
020305	FIRE SUPPRESSION SYSTEM	Test					4.0		E, G
		Inspect	1.0						E
		Repair					4.0	1, 14, 15	G
		Replace					40.0		G
0204	PERSONNEL SHELTER								

Table 1. MAC for Modular Causeway System. (MCS) (Continued)

(1) GROUP NO.	(2) COMPONENT/ASSEMBLY	(3) MAINTENANCE FUNCTION	(4) MAINTENANCE LEVEL					(5) TOOLS AND EQUIP REF CODE	(6) REMARKS CODE
			UNIT		DS	GS	DEPOT		
			C	O	F	H	D		
020401	HEAT PUMP	Clean		4.0				1	E
		Inspect		1.0				1	E
		Service			3.0			7, 21	E
		Repair		2.0	4.0			1, 7, 14, 15, 21	
		Replace			8.0			7, 14, 15, 21	
		Rebuild				8.0		7, 14, 15, 21	
020402	INCINOLET							AE	
020403	ELECTRICAL SYSTEM	Inspect	2.0						E
		Repair		12.0	3.0			1, 7, 14, 15	
		Replace			12.0			7, 14, 15	
020404	COMMUNICATIONS EQUIPMENT								
02040401	VHF/FM HANDHELD TRANSCEIVER	Replace	1.0						
		Repair				8.0			
0205	LIGHT TOWER								
020501	ELECTRICAL SYSTEM	Inspect			0.5			10, 15	E
		Test			1.0			10, 15	E
02050101	BATTERIES	Repair			6.0			10, 15	
		Test			1.0			10, 13	E
		Inspect	0.5						E
		Replace		2.0			1		

Table 1. MAC for Modular Causeway System. (MCS) (Continued)

(1) GROUP NO.	(2) COMPONENT/ASSEMBLY	(3) MAINTENANCE FUNCTION	(4) MAINTENANCE LEVEL					(5) TOOLS AND EQUIP REF CODE	(6) REMARKS CODE
			UNIT		DS	GS	DEPOT		
			C	O	F	H	D		
02050102	OIL PRESSURE UNIT	Test			1.0			10	E
		Repair			1.0			10	
		Replace			1.5			10	
02050103	STARTING CIRCUIT	Repair			2.0			10, 15	
		Replace			3.0			10, 15	
02050104	ENGINE TEMPERATURE UNIT	Test			1.0			10, 18	E
		Replace			2.5			10, 18	
		Repair			2.0			10, 18	
02050105	HOUR METER UNIT	Repair			1.5			10	
		Replace			2.0			10	
02050106	SHUTDOWN CIRCUIT	Repair			2.0			10	
		Replace			4.0			10	
02050107	LAMP SYSTEM	Test	1.0						E
		Repair			2.0			10, 15	
		Replace			6.0			10, 15	
02050108	LAMP BALLAST SYSTEM	Test			0.5			10, 15	E
		Repair			2.0			10, 15	
		Replace			3.0			10, 15	
020502	GENERATOR	Clean		2.0				1	E
		Inspect					12.0		
		Repair					18.0		
		Replace					24.0		

Table 1. MAC for Modular Causeway System. (MCS) (Continued)

(1) GROUP NO.	(2) COMPONENT/ASSEMBLY	(3) MAINTENANCE FUNCTION	(4) MAINTENANCE LEVEL					(5) TOOLS AND EQUIP REF CODE	(6) REMARKS CODE
			UNIT		DS	GS	DEPOT		
			C	O	F	H	D		
02050202	CONTROL PANEL	Inspect	1.0						E
		Repair			3.0			10, 15	
		Replace			4.5			10, 15	
02050205	DIESEL ENGINE	Service	4.0	2.0				1	E
		Adjust		3.0				1	
		Overhaul					16.0		
		Repair				16.0		10	
		Replace			16.0			10	
		Inspect	1.0						
0205020501	ENGINE FUEL SYSTEM	Inspect	1.0						E
		Repair		4.0				1	
		Replace			8.0			10	
020502050101	FUEL PUMP	Inspect	1.0						E
		Repair				4.0		10	
		Replace			5.0			10	
020502050102	FUEL TANK	Clean	2.0						E
		Inspect	1.0						E
		Repair		2.0				1	
		Replace		2.0				1	
0205020502	ENGINE AIR SYSTEM	Inspect	1.0						E
		Repair		2.0				1	
		Replace		4.0				1	
0205020503	ENGINE COOLING SYSTEM	Inspect	1.0						E
		Repair		3.0				1	
		Replace		2.0		5.0		1, 10	

Table 1. MAC for Modular Causeway System. (MCS) (Continued)

(1) GROUP NO.	(2) COMPONENT/ASSEMBLY	(3) MAINTENANCE FUNCTION	(4) MAINTENANCE LEVEL					(5) TOOLS AND EQUIP REF CODE	(6) REMARKS CODE
			UNIT		DS	GS	DEPOT		
			C	O	F	H	D		
020502050301	FAN ASSEMBLY	Inspect	0.5						E
		Repair		1.5				1	
		Replace		2.0				1	
020502050302	COOLING WATER PUMP	Inspect			1.0			10	E
		Repair				4.0		10	
		Replace			5.0			10	
020502050303	RADIATOR	Clean	1.0						E
		Inspect		1.0				1	
		Service	2.0	4.0				1	
		Repair				4.0		10	
		Replace		2.0	3.0			1, 10	
0205020504	CYLINDER HEAD	Inspect		1.0				1	E
		Adjust					2.0		
		Repair					8.0		
		Replace					5.0		
0205020505	VIBRATION DAMPER	Repair					4.0		
		Replace					4.0		
0205020506	EXHAUST SYSTEM	Clean	1.5						E
		Inspect	1.0						
		Repair		3.0				1, 16	
		Replace		5.0				1	
0205020507	CRANKSHAFT	Inspect					4.0		
		Repair					8.0		
		Replace					8.0		

Table 1. MAC for Modular Causeway System. (MCS) (Continued)

(1) GROUP NO.	(2) COMPONENT/ASSEMBLY	(3) MAINTENANCE FUNCTION	(4) MAINTENANCE LEVEL					(5) TOOLS AND EQUIP REF CODE	(6) REMARKS CODE
			UNIT		DS	GS	DEPOT		
			C	O	F	H	D		
0205020508	PISTON	Inspect					4.0		
		Repair					4.0		
		Replace					4.0		
02050206	RUNNING GEAR	Service		2.0				1	E
		Repair		2.0		2.0		1, 10	
		Replace		18.0				1	
0205020601	TIRES	Inspect	0.5						E
		Repair				1.0		10	
		Replace				1.0		10	
02050207	SUPPORT TOWER	Inspect	0.5						E
		Service	1.0						E
		Repair			2.0			10	
		Replace			6.0			10	
02050208	TOWER RAISING ASSEMBLY	Inspect	0.5						E
		Repair			1.0			10	
		Replace			3.0			10	
02050209	ENCLOSURE	Inspect	0.5						E
		Repair			2.0			10	
		Replace			6.0			10	
0206	EASY ANCHOR	Inspect	2.0						E
		Service		1.0				1	E
		Repair			4.0			6, 7	
		Replace			6.0			6, 7	
0207	RHIB (ZODIAC)								

Table 1. MAC for Modular Causeway System. (MCS) (Continued)

(1) GROUP NO.	(2) COMPONENT/ASSEMBLY	(3) MAINTENANCE FUNCTION	(4) MAINTENANCE LEVEL					(5) TOOLS AND EQUIP REF CODE	(6) REMARKS CODE
			UNIT		DS	GS	DEPOT		
			C	O	F	H	D		
020701	STEERING & THROTTLE	Inspect	1.0						E
		Service	1.0						E
		Repair			4.0			10	
		Replace			8.0			10	
020702	CONTROL PANEL	Inspect			2.0			10, 15	E
		Repair			4.0			10, 15	
		Replace			6.0			10, 15	
020703	BOAT HULL	Inspect	1.0						E
		Repair		2.0		20.0		1, 219-230	
		Replace				18.0		1, 219-230	
020704	NAVIGATION SYSTEM	Repair			3.0		12.0	7	
		Replace		2.0				1	
020705	OUTBOARD ENGINE	Test		4.0					E
		Repair					12.0		
		Rebuild					12.0		
		Replace		4.0					
02070501	ENGINE COVER	Inspect	1.0						E
		Repair			2.0			10	
		Replace			2.0			10	
02070502	LOWER ENGINE COVER	Inspect	1.0						E
		Repair			2.0			10	
		Replace			2.0			10	

Table 1. MAC for Modular Causeway System. (MCS) (Continued)

(1) GROUP NO.	(2) COMPONENT/ASSEMBLY	(3) MAINTENANCE FUNCTION	(4) MAINTENANCE LEVEL					(5) TOOLS AND EQUIP REF CODE	(6) REMARKS CODE
			UNIT		DS	GS	DEPOT		
			C	O	F	H	D		
02070503	ELECTRICAL STARTER	Repair			2.0			10, 15	
		Replace			3.0			10, 15	
02070504	POWER TRIM/TILT ELECTRICAL	Adjust		1.0				1	
		Repair			2.0			10, 15	
		Replace			2.5			10, 15	
02070505	IGNITION	Repair					8.0		
		Replace					8.0	2, 17	
02070506	INTAKE MANIFOLD	Inspect			1.0			10	E
		Repair			3.0			10	
		Replace			3.0			10	
02070507	CARBURETOR	Adjust		1.0				1	
		Repair			3.0			10	
		Replace			3.0			10	
02070508	ELECTRIC PRIMER SYSTEM	Repair			3.0			10, 15	
		Replace			2.0			10, 15	
02070509	FUEL TANK	Inspect	1.0						E
		Repair			3.0			10	
		Replace	2.0						
02070510	FUEL HOSE & PRIMER BULB	Repair		1.0				1	
		Replace	1.0						
02070511	FUEL PUMP	Repair			2.0			10	
		Replace			2.0			10	

Table 1. MAC for Modular Causeway System. (MCS) (Continued)

(1) GROUP NO.	(2) COMPONENT/ASSEMBLY	(3) MAINTENANCE FUNCTION	(4) MAINTENANCE LEVEL					(5) TOOLS AND EQUIP REF CODE	(6) REMARKS CODE
			UNIT		DS	GS	DEPOT		
			C	O	F	H	D		
02070512	CRANKSHAFT & PISTON	Inspect					6.0		
		Repair					8.0		
		Replace					8.0		
02070513	CYLINDER & CRANKCASE	Inspect					6.0		
		Rebuild					16.0		
		Replace					8.0		
02070514	EXHAUST HOUSING	Inspect	1.0						E
		Repair			3.0			10	
		Replace			3.0			10	
02070515	POWER TRIM/TILT HYDRAULIC	Repair					4.0		
		Replace					3.0		
02070516	POWER TRIM/TILT MIDSECTION	Inspect					2.0		
		Repair					4.0		
		Replace					4.0		
02070517	GEARCASE	Inspect			3.0			10	E
		Repair					8.0		
		Replace					8.0		
0207051701	BEARING HOUSING ASSEMBLY	Inspect					2.0		
		Repair					3.0		
		Replace					3.0		

Table 1. MAC for Modular Causeway System. (MCS) (Continued)

(1) GROUP NO.	(2) COMPONENT/ASSEMBLY	(3) MAINTENANCE FUNCTION	(4) MAINTENANCE LEVEL					(5) TOOLS AND EQUIP REF CODE	(6) REMARKS CODE
			UNIT		DS	GS	DEPOT		
			C	O	F	H	D		
0207051702	PROPELLER SHAFT ASSEMBLY	Inspect					2.0		
		Repair					4.0		
		Replace					3.0		
0207051703	IMPELLER ASSEMBLY	Inspect					4.0		
		Repair					4.0		
		Replace					4.0		
0207051704	WATER PUMP ASSEMBLY	Inspect					4.0		
		Repair					4.0		
		Rebuild					8.0		
		Replace					4.0		
02070518	STEERING LINK KIT	Inspect	1.0						E
		Repair		1.0				1	
		Replace		2.0				1	
02070519	BATTERY	Test			2.0			10, 13	
		Service			2.0			10	
		Replace			2.0			10	
0207051901	BATTERY CABLE	Clean	0.5						
		Inspect	0.5						E
		Repair		1.0				1	
		Replace		1.0				1	
020706	FIRE EXTINGUISHER	Inspect	0.5						E
		Replace	2.0						E

Table 1. MAC for Modular Causeway System. (MCS) (Continued)

(1) GROUP NO.	(2) COMPONENT/ASSEMBLY	(3) MAINTENANCE FUNCTION	(4) MAINTENANCE LEVEL					(5) TOOLS AND EQUIP REF CODE	(6) REMARKS CODE
			UNIT		DS	GS	DEPOT		
			C	O	F	H	D		
0208	CONTAINERS	Inspect	2.0						E
		Clean	1.0						E
		Repair			4.0			7	
		Replace					8.0		

Table 1. MAC for Modular Causeway System. (MCS) (Continued)

(1) GROUP NO.	(2) COMPONENT/ASSEMBLY	(3) MAINTENANCE FUNCTION	(4) MAINTENANCE LEVEL					(5) TOOLS AND EQUIP REF CODE	(6) REMARKS CODE
			UNIT		DS	GS	DEPOT		
			C	O	F	H	D		

Table 1. MAC for Modular Causeway System. (MCS) (Continued)

(1) GROUP NO.	(2) COMPONENT/ASSEMBLY	(3) MAINTENANCE FUNCTION	(4) MAINTENANCE LEVEL				(5) TOOLS AND EQUIP REF CODE	(6) REMARKS CODE	
			UNIT		DS	GS			DEPOT
			C	O	F	H			D
00	MODULAR CAUSEWAY SYSTEM (MCS)								
01	CAUSEWAY FERRY (CF)								
02	ROLL-ON/ROLL-OFF DISCHARGE FACILITY (RRDF)								
03	MODULAR WARPING TUG (WT)								
0301	POWERED SECTION								
030101	POWERED MODULE								
03010101	DRIVE TRAIN								
0301010101	DIESEL ENGINE							Z	
0301010102	MARINE GEAR							AA	
0301010103	TRANSFER CASE							AB	
0301010104	PUMP-JET ASSEMBLY	Inspect	0.5					E	
		Service		3.0			1	E	
		Repair				10.0		D	
		Replace				50.0			
030101010401	HYDRAULIC SYSTEM	Inspect	1.0				1	E	
		Service	1.0	3.0			1	E	
		Repair			3.0		2, 4, 7		
		Replace			6.0		2, 4, 7		

Table 1. MAC for Modular Causeway System. (MCS) (Continued)

(1) GROUP NO.	(2) COMPONENT/ASSEMBLY	(3) MAINTENANCE FUNCTION	(4) MAINTENANCE LEVEL					(5) TOOLS AND EQUIP REF CODE	(6) REMARKS CODE
			UNIT		DS	GS	DEPOT		
			C	O	F	H	D		
03010101040101	HYDRAULIC PUMP	Test	0.5						E
		Inspect	1.0						E
		Repair				4.0		2, 4, 7	
		Replace		6.0				1, 2, 4	
03010101040102	HYDRAULIC HAND PUMP	Inspect	1.0						E
		Repair					20.0		
		Replace		2.0				1, 2, 4	
03010101040103	HYDRAULIC WAY-VALVE	Repair				2.0		2, 4, 7	
		Replace		1.5				1, 2, 4	
030101010402	FEEDBACK UNIT	Inspect	1.0						E
		Repair				2.5		2, 4, 7	
		Replace			2.0			2, 4, 7	
0301010105	ALTERNATOR	Test			1.0			7, 14, 15	E
		Inspect	0.5						E
		Replace			2.0			7, 14, 15	
03010102	ENGINE EXHAUST SYSTEM	Clean		2.0				1, 3, 9	E
		Inspect		2.0				1, 3, 9	E
		Repair			6.0			3, 7, 9	
03010103	BILGE PUMP SYSTEM	Test		2.0				1	E
		Inspect	1.0						E
03010104	FIRE SUPPRESSION SYSTEM	Test					3.0		E
		Inspect	2.0				3.0		E

Table 1. MAC for Modular Causeway System. (MCS) (Continued)

(1) GROUP NO.	(2) COMPONENT/ASSEMBLY	(3) MAINTENANCE FUNCTION	(4) MAINTENANCE LEVEL					(5) TOOLS AND EQUIP REF CODE	(6) REMARKS CODE
			UNIT		DS	GS	DEPOT		
			C	O	F	H	D		
03010104	FIRE SUPPRESSION SYSTEM (CONT'D)	Repair					8.0		G
		Replace					24.0		G
03010105	FUEL SYSTEM	Test	1.0						E
		Inspect	1.0						E
		Repair			4.0			7	
		Replace			12.0			7	
0301010501	FUEL/WATER SEPARATOR	Clean	1.0						E
		Inspect	1.0						E
		Repair		2.0				1	
		Replace			4.0			7	
03010106	ELECTRICAL SYSTEM	Test			1.0			7, 14, 15	E
		Adjust			1.0			7, 14, 15	
		Repair			2.0			7, 14, 15	
		Replace			8.0			7, 14, 15	
03010107	EMERGENCY STEERING SYSTEM	Inspect	2.0						E
		Service	1.0						E
		Replace		4.0				1	
0301010701	STEERING UNIT	Inspect	0.5						E
		Replace		2.0				1	
0301010702	STEERING ADAPTOR	Inspect	0.5						E
		Replace		1.5				1	
03010108	HULL								

Table 1. MAC for Modular Causeway System. (MCS) (Continued)

(1) GROUP NO.	(2) COMPONENT/ASSEMBLY	(3) MAINTENANCE FUNCTION	(4) MAINTENANCE LEVEL				(5) TOOLS AND EQUIP REF CODE	(6) REMARKS CODE	
			UNIT		DS	GS			DEPOT
			C	O	F	H			D
0301010801	EXTERIOR	Clean		4.0				8, 9, 23, 24	E
		Inspect	1.0						E
		Service	1.5						E
		Repair		4.0				1, 16	
		Overhaul					24.0		
0301010802	INTERIOR	Clean					4.0		
		Inspect					2.0		
		Test					5.0	1, 25, 26	E
		Repair					6.0		
		Overhaul					50.0		
03010109	GUILLOTINE FITTINGS	Clean		1.0				8, 9, 23, 24	E
		Inspect	0.5						E
		Repair		3.0				1, 16	
		Replace		1.0				1	
03010110	HATCHES & HINGES	Clean	1.0						E
		Inspect	0.5					1	E
		Service	0.5						E
		Repair		2.0				1, 16	
		Replace		2.0				1	
03010111	FLEXORS	Inspect	0.5						E
		Replace	4.0						
030102	NON-POWERED MODULE								
03010201	HULL								

Table 1. MAC for Modular Causeway System. (MCS) (Continued)

(1) GROUP NO.	(2) COMPONENT/ASSEMBLY	(3) MAINTENANCE FUNCTION	(4) MAINTENANCE LEVEL					(5) TOOLS AND EQUIP REF CODE	(6) REMARKS CODE
			UNIT		DS	GS	DEPOT		
			C	O	F	H	D		
0301020101	EXTERIOR	Clean		4.0				8, 9, 23, 24	E
		Inspect	1.0						E
		Service	1.5						E
		Repair		4.0				1, 16	
		Overhaul					24.0		
0301020102	INTERIOR	Clean					4.0		
		Inspect					2.0		
		Test		8.0			5.0	1, 25, 26	E
		Repair					6.0		
		Overhaul					50.0		
03010202	GUILLOTINE FITTINGS	Clean		1.0				8, 9, 23, 24	E
		Inspect	0.5						E
		Repair		3.0				1, 16	
		Replace	1.0					1	
030103	OPERATORS CAB								
03010301	MIDDLE CONTROL PANEL	Test			2.0			7, 14, 15	E
		Inspect			2.0			7, 14, 15	E
		Repair			3.0			7, 14, 15	
		Replace			16.0			7, 14, 15	
03010302	LOWER CONTROL PANEL	Test			2.0			7, 14, 15	E
		Inspect			2.0			7, 14, 15	E
		Repair			3.0			7, 14, 15	
		Replace			16.0			7, 14, 15	

Table 1. MAC for Modular Causeway System. (MCS) (Continued)

(1) GROUP NO.	(2) COMPONENT/ASSEMBLY	(3) MAINTENANCE FUNCTION	(4) MAINTENANCE LEVEL					(5) TOOLS AND EQUIP REF CODE	(6) REMARKS CODE
			UNIT		DS	GS	DEPOT		
			C	O	F	H	D		
03010303	CIRCUIT BREAKER PANEL	Test			1.0			7, 14, 15	E
		Inspect			1.0			7, 14, 15	E
		Repair			2.0			7, 14, 15	
		Replace			12.0			7, 14, 15	
03010304	TERMINAL BOARD A-4	Test			1.0			7, 14, 15	E
		Inspect			1.0			7, 14, 15	E
		Repair			2.0			7, 14, 15	
		Replace			10.0			7, 14, 15	
03010305	SPOTLIGHT	Adjust		1.0				1	
		Replace		1.0				1	
03010306	DEFROSTER	Inspect	1.0						E
		Replace			4.0			7, 14, 15	
03010307	HEATER	Inspect		2.0				1	E
		Repair			4.0			7, 14, 15	
		Replace			6.0			7, 14, 15	
03010308	WINDSHIELD WIPER	Repair		1.0				1	
		Replace		2.0				1	
03010309	COMMUNICATIONS EQUIPMENT								
0301030901	VHF/FM HANDHELD TRANSCEIVER	Repair					8.0		
		Replace		1.0				1	

Table 1. MAC for Modular Causeway System. (MCS) (Continued)

(1) GROUP NO.	(2) COMPONENT/ASSEMBLY	(3) MAINTENANCE FUNCTION	(4) MAINTENANCE LEVEL					(5) TOOLS AND EQUIP REF CODE	(6) REMARKS CODE
			UNIT		DS	GS	DEPOT		
			C	O	F	H	D		
0301030902	AN/PSN-11 INTERFACE & SWITCHBOX	Repair					6.0		
		Replace			1.0			7, 14, 15	
0301030903	LOUDHAILER	Test	0.5						E
		Repair					8.0		
		Replace	0.5						
0301030904	SINGARS RADIO								H
0301030905	VHF/FM DSC TRANSCEIVER	Repair					12.0		
		Replace		1.0				1	
03010310	NAVIGATION EQUIPMENT	Test	0.5						E
		Inspect	1.0						E
0301031001	COMPASS	Inspect	2.0						E
		Replace		2.0				1	
		Calibrate		4.0				1	
0301031002	PLGR								I
03010311	MAST	Inspect	3.0						E
		Repair		3.0				1	
0301031101	NAVIGATION LIGHTS	Repair		1.0				1	
		Replace		1.0				1	
03010312	OPERATORS CAB ELECTRICAL SYSTEM	Test			4.0			7, 14, 15	E
		Inspect			4.0			7, 14, 15	E
		Repair				6.0		7, 14, 15	
		Replace			10.0			7, 14, 15	

Table 1. MAC for Modular Causeway System. (MCS) (Continued)

(1) GROUP NO.	(2) COMPONENT/ASSEMBLY	(3) MAINTENANCE FUNCTION	(4) MAINTENANCE LEVEL					(5) TOOLS AND EQUIP REF CODE	(6) REMARKS CODE
			UNIT		DS	GS	DEPOT		
			C	O	F	H	D		
030104	ANCHOR ASSEMBLY	Inspect	1.0						E
		Repair		1.0				1	
		Replace		1.0				1	
0302	CONTAINERS	Clean	1.0						E
		Inspect	2.0						E
		Repair			4.0			7	
		Replace					8.0		
0303	WINCH								AC
030301	WINCH DIESEL ENGINE								AD
030302	WINCH ASSEMBLY	Clean			8.0			7	E
		Test			4.0			7	E
		Inspect			4.0			7	E
		Service	4.0						
		Repair			4.0			7	
		Replace	3.0						

Table 1. MAC for Modular Causeway System. (MCS) (Continued)

(1) GROUP NO.	(2) COMPONENT/ASSEMBLY	(3) MAINTENANCE FUNCTION	(4) MAINTENANCE LEVEL					(5) TOOLS AND EQUIP REF CODE	(6) REMARKS CODE
			UNIT		DS	GS	DEPOT		
			C	O	F	H	D		
00	MODULAR CAUSEWAY SYSTEM (MCS)								
01	CAUSEWAY FERRY (CF)								
02	ROLL-ON/ROLL-OFF DISCHARGE FACILITY (RRDF)								
03	MODULAR WARPING TUG (WT)								
0301010101	DIESEL ENGINE	Inspect	4.0						E
		Service	4.0	4.0					E
		Repair				30.0		7, 27-218	
		Replace			120.0			7, 27-218	
		Overhaul					80.0		
030101010101	ENGINE BLOCK ASSEMBLY	Inspect	2.0						E, J
		Repair				6.0		7, 27-52	J
		Replace				120.0		7, 27-52	J
030101010102	CYLINDER HEAD ASSEMBLY	Clean				5.0		7, 53-85	K
		Inspect			6.0			7, 53-85	K
		Repair				12.0		7, 53-85	K
		Replace			8.0			7, 53-85	K
030101010103	CRANKSHAFT ASSEMBLY	Repair			16.0			7, 86-106	L
		Replace			24.0			7, 86-106	L
030101010104	CAMSHAFT ASSEMBLY	Repair				12.0		7, 131-141	
		Replace				16.0		7, 131-141	

Table 1. MAC for Modular Causeway System. (MCS) (Continued)

(1) GROUP NO.	(2) COMPONENT/ASSEMBLY	(3) MAINTENANCE FUNCTION	(4) MAINTENANCE LEVEL					(5) TOOLS AND EQUIP REF CODE	(6) REMARKS CODE
			UNIT		DS	GS	DEPOT		
			C	O	F	H	D		
030101010105	FLYWHEEL ASSEMBLY	Inspect			3.0			7, 107-112	M
		Repair				3.0		7, 107-112	M
		Replace			5.0			7, 107-112	M
030101010106	PISTON ASSEMBLY	Clean				2.0		7, 113-130	N
		Inspect				2.0		7, 113-130	N
		Rebuild				4.5		7, 113-130	N
		Replace				3.0		7, 113-130	N
		Inspect				6.0		7, 131-141	O
030101010107	ENGINE BALANCE	Adjust				3.0		7, 131-141	O
		Repair				8.0		7, 131-141	O
		Replace				8.0		7, 131-141	O
		Inspect	0.5						E, P
03010101010801	FUEL PUMP	Inspect			1.0			7, 142-187	E
		Repair			4.0			7, 142-187	
		Replace			2.0			7, 142-187	
03010101010802	PRIMING PUMP	Inspect		1.5				1, 142-187	E
		Replace		2.0				1, 142-187	
030101010109	ELECTRIC GOVERNOR	Test		0.5					E
		Adjust			1.0			7, 142-187	
		Repair					5.0		
		Replace		2.0				1, 142-187	
		Clean		2.0				1, 188-195	E, Q
030101010110	AIR INTAKE SYSTEM	Inspect	0.5						E, Q
		Replace		3.0				1, 188-195	Q

Table 1. MAC for Modular Causeway System. (MCS) (Continued)

(1) GROUP NO.	(2) COMPONENT/ASSEMBLY	(3) MAINTENANCE FUNCTION	(4) MAINTENANCE LEVEL					(5) TOOLS AND EQUIP REF CODE	(6) REMARKS CODE
			UNIT		DS	GS	DEPOT		
			C	O	F	H	D		
03010101011001	BLOWER	Inspect			2.0	2.0		7, 188-195	E
		Adjust				4.0		7, 188-195	
		Repair				18.0		7, 188-195	
		Replace			8.0			7, 188-195	
03010101011002	TURBOCHARGER	Inspect			2.0			1, 188-195	E, R
		Repair					18.0		
		Replace			6.0			7, 188-195	
030101010111	LUBE OIL SYSTEM	Service	5.0	5.0					E, S
		Inspect	1.0						E, S
03010101011101	LUBE OIL PUMP	Inspect				3.0		7, 196-203	E
		Repair				4.0		7, 196-203	
		Replace				4.0		7, 196-203	
03010101011102	LUBE OIL COOLER	Clean			2.0			7	E
		Test			1.5			7, 25, 26	E
		Inspect			2.0			7	E
		Repair			4.0			7	
		Replace			2.0			7	
030101010112	FRESH WATER COOLING SYSTEM	Inspect	1.0						E, T
		Clean		1.0				1	
03010101011201	FRESH WATER PUMP	Inspect			2.5			7, 212-215	E
		Repair			6.0			7, 212-215	
		Replace			3.0			7, 212-215	

Table 1. MAC for Modular Causeway System. (MCS) (Continued)

(1) GROUP NO.	(2) COMPONENT/ASSEMBLY	(3) MAINTENANCE FUNCTION	(4) MAINTENANCE LEVEL					(5) TOOLS AND EQUIP REF CODE	(6) REMARKS CODE
			UNIT		DS	GS	DEPOT		
			C	O	F	H	D		
03010101011202	FRESH WATER COOLER	Clean			2.0			7	E
		Test			2.0			7, 25, 26	E
		Inspect			1.0			7	E
		Repair			4.0			7	
		Replace			3.0			7	
030101010113	RAW WATER COOLING SYSTEM	Clean	1.0						E, U
		Inspect		2.0				1	E, U
03010101011301	RAW WATER PUMP	Inspect		2.0				1	E
		Repair			4.0			7, 212-215	
		Replace		2.5				1, 211-215	
030101010114	ELECTRICAL SYSTEM	Test			4.0			7, 14, 15	E, V
		Inspect			2.0			7, 14, 15	E, V
		Repair			3.0			7, 14, 15	V
		Replace		4.0	16.0			1, 7, 14, 15	V
03010101011401	STARTER	Inspect	1.0						E
		Repair				6.0		7, 14, 15	
		Replace		3.0				1, 14, 15	
03010101011402	COLD PACK STARTER	Clean		1.0				1	E
		Inspect	0.5						E
		Adjust		1.0				1, 14, 15	
		Repair		2.5				1, 14, 15	
		Replace		3.0				1, 14, 15	

Table 1. MAC for Modular Causeway System. (MCS) (Continued)

(1) GROUP NO.	(2) COMPONENT/ASSEMBLY	(3) MAINTENANCE FUNCTION	(4) MAINTENANCE LEVEL					(5) TOOLS AND EQUIP REF CODE	(6) REMARKS CODE
			UNIT		DS	GS	DEPOT		
			C	O	F	H	D		
030101010115	OVER SPEED GOVERNOR	Test				1.0		7	E
		Adjust				1.5		7, 184-187	
		Repair				5.0		7, 184-187	
		Replace				4.0		7, 184-187	
030101010116	AUTO SHUTDOWN SYSTEM	Test		1.0					E
		Adjust			2.0			7, 14, 15	
		Repair				6.0		7, 14, 15	
		Replace		4.0			8.0	1	

Table 1. MAC for Modular Causeway System. (MCS) (Continued)

(1) GROUP NO.	(2) COMPONENT/ASSEMBLY	(3) MAINTENANCE FUNCTION	(4) MAINTENANCE LEVEL					(5) TOOLS AND EQUIP REF CODE	(6) REMARKS CODE
			UNIT		DS	GS	DEPOT		
			C	O	F	H	D		

Table 1. MAC for Modular Causeway System. (MCS) (Continued)

(1) GROUP NO.	(2) COMPONENT/ASSEMBLY	(3) MAINTENANCE FUNCTION	(4) MAINTENANCE LEVEL					(5) TOOLS AND EQUIP REF CODE	(6) REMARKS CODE
			UNIT		DS	GS	DEPOT		
			C	O	F	H	D		
00	MODULAR CAUSEWAY SYSTEM (MCS)								
01	CAUSEWAY FERRY (CF)								
02	ROLL-ON/ROLL-OFF DISCHARGE FACILITY (RRDF)								
03	MODULAR WARPING TUG (WT)								
0301010102	MARINE GEAR	Inspect	1.0						E
		Align			2.0			7, 17	
		Service	1.0	4.0				1	E
		Replace			28.0			4, 7, 17	
		Rebuild					25.0		W
030101010201	OIL SYSTEM	Inspect	0.5						E, X
		Repair		0.5				1, 11	X
03010101020101	OIL COOLER	Clean	1.0						E
		Inspect	1.0						E
		Replace		4.0				1	
03010101020102	LINES & HOSES	Inspect	0.2						E
		Repair		0.5				1	
		Replace		2.0				1	
03010101020103	OIL PUMP	Inspect	1.0						E
		Replace			2.0			1, 3	
03010101020104	ELECTRIC CONTROL VALVE	Repair				8.0			
		Replace			6.0			7, 14, 15	

Table 1. MAC for Modular Causeway System. (MCS) (Continued)

(1) GROUP NO.	(2) COMPONENT/ASSEMBLY	(3) MAINTENANCE FUNCTION	(4) MAINTENANCE LEVEL					(5) TOOLS AND EQUIP REF CODE	(6) REMARKS CODE
			UNIT		DS	GS	DEPOT		
			C	O	F	H	D		
030101010202	GEAR MOUNTS	Inspect	0.5						E
		Replace			2.0			3, 7	
030101010203	COUPLING BLOCKS	Clean			1.0			7	E
		Inspect			1.0			7	E
		Replace			4.0			3, 7	
030101010204	OUTPUT FLANGE	Inspect	0.5						E
		Align			2.0			3, 7, 17	
		Replace			4.0			3, 7, 17	
030101010205	OUTPUT SEAL	Inspect			2.0			7	E
		Replace			2.0			3, 7	
030101010206	INPUT FLANGE (ENGINE CONNECTION)	Inspect	0.5						E

Table 1. MAC for Modular Causeway System. (MCS) (Continued)

(1) GROUP NO.	(2) COMPONENT/ASSEMBLY	(3) MAINTENANCE FUNCTION	(4) MAINTENANCE LEVEL					(5) TOOLS AND EQUIP REF CODE	(6) REMARKS CODE
			UNIT		DS	GS	DEPOT		
			C	O	F	H	D		
00	MODULAR CAUSEWAY SYSTEM (MCS)								
01	CAUSEWAY FERRY (CF)								
02	ROLL-ON/ROLL-OFF DISCHARGE FACILITY (RRDF)								
03	MODULAR WARPING TUG (WT)								
0301010103	TRANSFER CASE	Clean		2.0				1	E
		Service	1.0	4.0				1	E
		Overhaul				24.0			
		Rebuild					24.0	2, 7, 17	Y
		Replace			24.0			2, 7, 17	
030101010301	OIL SYSTEM	Inspect	1.0						E
		Repair		2.5				1	
03010101030101	OIL PUMP	Inspect	4.0						E
		Replace		2.5				1	
03010101030102	HOSES & FITTINGS	Inspect	0.2						E
		Replace		2.0				1	
03010101030103	OIL COOLER	Inspect	0.2						E
		Replace		3.5				1	
030101010302	GEAR SHAFT	Inspect				5.0		7	E
		Repair				8.0		3, 7, 17	
		Replace				7.0		3, 7, 17, 19	

Table 1. MAC for Modular Causeway System. (MCS) (Continued)

(1) GROUP NO.	(2) COMPONENT/ASSEMBLY	(3) MAINTENANCE FUNCTION	(4) MAINTENANCE LEVEL					(5) TOOLS AND EQUIP REF CODE	(6) REMARKS CODE
			UNIT		DS	GS	DEPOT		
			C	O	F	H	D		
03010101030201	UPPER SHAFT	Inspect				5.0		7	E
		Repair				8.0		3, 7, 17	
		Replace				7.0		3, 7, 17, 19	
0301010103020101	INPUT SEAL	Clean			2.0			7	E
		Inspect			2.0			7	E
		Replace			2.0			3, 7, 17, 19	
0301010103020102	OUTPUT SEAL	Clean			2.0			7	E
		Inspect			2.0			7	E
		Replace			2.0			3, 7, 17, 19	
03010101030202	INTERMEDIATE SHAFT	Inspect				2.5		7	E
		Repair				5.5		3, 7, 17	
		Replace				6.5		3, 7, 17, 19	
03010101030203	LOWER SHAFT	Inspect				4.0		7	E
		Repair				8.0		3, 7, 17	
		Replace				6.0		3, 7, 17, 19	
0301010103020301	INPUT SEAL	Clean			2.0			7	E
		Inspect			2.0			7	E
		Replace			2.0			3, 7, 17, 19	

Table 1. MAC for Modular Causeway System. (MCS) (Continued)

(1) GROUP NO.	(2) COMPONENT/ASSEMBLY	(3) MAINTENANCE FUNCTION	(4) MAINTENANCE LEVEL					(5) TOOLS AND EQUIP REF CODE	(6) REMARKS CODE
			UNIT		DS	GS	DEPOT		
			C	O	F	H	D		
00	MODULAR CAUSEWAY SYSTEM (MCS)								
01	CAUSEWAY FERRY (CF)								
02	ROLL-ON/ROLL- OFF DISCHARGE FACILITY (RRDF)								
04	FLOATING CAUSEWAY (FC)								
0401	INTERMEDIATE SECTION								
040101	NON-POWERED MODULE								
04010101	HULL								
0401010101	EXTERIOR	Clean		4.0				8, 9, 23, 24	E
		Inspect	1.0						E
		Service	1.5						E
		Repair		4.0				1, 16	
		Overhaul					24.0		
0401010102	INTERIOR	Clean					4.0		
		Inspect					2.0		
		Test		6.0			5.0	1, 25, 26	E
		Repair					6.0		
		Overhaul					50.0		
04010102	GUILLOTINE FITTINGS	Clean		1.0				8, 9, 23, 24	E
		Inspect	0.5						E
		Repair		3.0				1, 16	

Table 1. MAC for Modular Causeway System. (MCS) (Continued)

(1) GROUP NO.	(2) COMPONENT/ASSEMBLY	(3) MAINTENANCE FUNCTION	(4) MAINTENANCE LEVEL				(5) TOOLS AND EQUIP REF CODE	(6) REMARKS CODE	
			UNIT		DS	GS			DEPOT
			C	O	F	H			D
04010102	GUILLOTINE FITTINGS (CONT'D)	Replace		1.0				1	
04010103	FLEXORS	Inspect	0.5						E
		Replace	4.0						
0402	COMBINATION BEACH-END SECTION								
040201	NON-POWERED MODULES								
04020101	HULL								
0402010101	EXTERIOR	Clean		4.0				8, 9, 23, 24	E
		Inspect	1.0						E
		Service	1.5						E
		Repair		4.0				1, 16	
		Overhaul					24.0		
0402010102	INTERIOR	Clean					4.0		
		Inspect					2.0		
		Test					5.0	1, 25, 26	E
		Repair					6.0		
		Overhaul					50.0		
04020102	GUILLOTINE FITTINGS	Clean		1.0				8, 9, 23, 24	E
		Inspect	0.5						E
		Repair		3.0				1, 16	
		Replace		1.0				1	
04020103	FLEXORS	Inspect	0.5						E
		Replace	4.0						

Table 1. MAC for Modular Causeway System. (MCS) (Continued)

(1) GROUP NO.	(2) COMPONENT/ASSEMBLY	(3) MAINTENANCE FUNCTION	(4) MAINTENANCE LEVEL					(5) TOOLS AND EQUIP REF CODE	(6) REMARKS CODE
			UNIT		DS	GS	DEPOT		
			C	O	F	H	D		
0403	GENERATOR SHELTER	Repair		4.0				1	
040301	ARMY TACTICAL QUIET GENERATOR (ATQG)								
040302	FUEL SYSTEM	Clean					1.0		E
		Inspect					1.0	7	
		Repair					5.0	1	
04030201	MANUAL FUEL PUMP	Clean		1.0				1	E
		Inspect	1.0	1.0				1	E
		Repair		2.0				1	
		Replace		2.0				1	
040303	LOUVERS	Clean		1.0				1	E
		Inspect	1.0						E
		Service		1.0					E
		Repair		3.0				1	
		Replace		4.0				1	
040304	ELECTRICAL SYSTEM	Test			2.0			7, 14, 15	E
		Repair		2.0	3.0			1, 7, 14, 15	
		Replace			5.0			7, 14, 15	
040305	FIRE SUPPRESSION SYSTEM	Test					4.0		E, G
		Inspect	1.0						E
		Repair		2.0			4.0	1, 14, 15	G
		Replace					40.0		G

Table 1. MAC for Modular Causeway System. (MCS) (Continued)

(1) GROUP NO.	(2) COMPONENT/ASSEMBLY	(3) MAINTENANCE FUNCTION	(4) MAINTENANCE LEVEL					(5) TOOLS AND EQUIP REF CODE	(6) REMARKS CODE
			UNIT		DS	GS	DEPOT		
			C	O	F	H	D		
0404	PERSONNEL SHELTER								
040401	HEAT PUMP	Clean		4.0				1	E
		Inspect		1.0				1	E
		Service			3.0			7, 21	E
		Repair			4.0			1, 7,14, 15, 21	
		Rebuild				8.0		7,14, 15, 21	
		Replace			8.0			7,14, 15, 21	
040402	INCINOLET								AE
040403	ELECTRICAL SYSTEM	Inspect	2.0						E
		Repair		12.0	3.0			1, 7, 14, 15	
		Replace			12.0			7, 14, 15	
040404	COMMUNICATIONS EQUIPMENT								
04040401	VHF/FM HANDHELD TRANSCEIVER	Replace	1.0					1	
		Repair					8.0		
0405	LIGHT TOWER								
040501	ELECTRICAL SYSTEM	Test			1.0			10, 15	E
		Inspect			0.5			10, 15	E
		Repair			6.0			10, 15	

Table 1. MAC for Modular Causeway System. (MCS) (Continued)

(1) GROUP NO.	(2) COMPONENT/ASSEMBLY	(3) MAINTENANCE FUNCTION	(4) MAINTENANCE LEVEL					(5) TOOLS AND EQUIP REF CODE	(6) REMARKS CODE
			UNIT		DS	GS	DEPOT		
			C	O	F	H	D		
04050101	BATTERIES	Test			1.0			10, 13	E
		Inspect	0.5						E
		Replace		2.0				1	
04050102	OIL PRESSURE UNIT	Test			1.0			10	E
		Repair			1.0			10	
		Replace			1.5			10	
04050103	STARTING CIRCUIT	Repair			2.0			10, 15	
		Replace			3.0			10, 15	
04050104	ENGINE TEMPERATURE UNIT	Test			1.0			10, 18	E
		Repair			2.0			10, 18	
		Replace			2.5			10, 18	
04050105	HOUR METER UNIT	Repair			1.5			10	
		Replace			2.0			10	
04050106	SHUTDOWN CIRCUIT	Repair			2.0			10	
		Replace			4.0			10	
04050107	LAMP SYSTEM	Test	1.0						E
		Repair			2.0			10, 15	
		Replace			6.0			10, 15	
04050108	LAMP BALLAST SYSTEM	Test			0.5			10, 15	E
		Repair			2.0			10, 15	
		Replace			3.0			10, 15	
040502	GENERATOR	Clean		2.0				1	E
		Inspect					12.0		

Table 1. MAC for Modular Causeway System. (MCS) (Continued)

(1) GROUP NO.	(2) COMPONENT/ASSEMBLY	(3) MAINTENANCE FUNCTION	(4) MAINTENANCE LEVEL					(5) TOOLS AND EQUIP REF CODE	(6) REMARKS CODE
			UNIT		DS	GS	DEPOT		
			C	O	F	H	D		
040502	GENERATOR (CONT'D)	Repair					18.0		
		Replace					24.0		
04050202	CONTROL PANEL	Test	1.0						E
		Inspect	1.0						E
		Repair			3.0			10, 15	
		Replace			4.5			10, 15	
04050205	DIESEL ENGINE	Service	4.0	2.0				1	E
		Adjust		3.0				1	
		Repair				16.0		10	
		Overhaul					16.0		
		Replace			16.0			10	
0405020501	ENGINE FUEL SYSTEM	Inspect	1.0						E
		Repair		4.0				1	
		Replace			8.0			10	
040502050101	FUEL PUMP	Inspect	1.0						E
		Repair				4.0		10	
		Replace			5.0			10	
040502050102	FUEL TANK	Clean	2.0						E
		Inspect	1.0						E
		Repair		2.0				1	
		Replace		2.0				1	
0405020502	ENGINE AIR SYSTEM	Inspect	1.0						E
		Repair		2.0				1	
		Replace		4.0				1	

Table 1. MAC for Modular Causeway System. (MCS) (Continued)

(1) GROUP NO.	(2) COMPONENT/ASSEMBLY	(3) MAINTENANCE FUNCTION	(4) MAINTENANCE LEVEL					(5) TOOLS AND EQUIP REF CODE	(6) REMARKS CODE
			UNIT		DS	GS	DEPOT		
			C	O	F	H	D		
0405020503	ENGINE COOLING SYSTEM	Inspect	1.0						E
		Repair		3.0				1	
		Replace		7.0				1, 10	
040502050301	FAN ASSEMBLY	Inspect	0.5						E
		Repair		1.5				1	
		Replace		2.0				1	
040502050302	COOLING WATER PUMP	Inspect						10	E
		Repair				4.0		10	
		Replace			5.0			10	
040502050303	RADIATOR	Clean	1.0						E
		Inspect		1.0				1	E
		Service	2.0	4.0				1	E
		Repair				4.0		10	
		Replace		2.0	3.0			1, 10	
0405020504	CYLINDER HEAD	Inspect		1.0				1	E
		Adjust					2.0		
		Repair					8.0		
		Replace					5.0		
0405020505	VIBRATION DAMPER	Repair					4.0		
		Replace					4.0		
0405020506	EXHAUST SYSTEM	Inspect	0.5						E
		Clean	1.5						E
		Repair			3.0			1, 16	
		Replace			5.0			1	

Table 1. MAC for Modular Causeway System. (MCS) (Continued)

(1) GROUP NO.	(2) COMPONENT/ASSEMBLY	(3) MAINTENANCE FUNCTION	(4) MAINTENANCE LEVEL					(5) TOOLS AND EQUIP REF CODE	(6) REMARKS CODE
			UNIT		DS	GS	DEPOT		
			C	O	F	H	D		
0405020507	CRANKSHAFT	Inspect					4.0		
		Repair					8.0		
		Replace					8.0		
0405020508	PISTON	Inspect					4.0		
		Repair					4.0		
		Replace					4.0		
04050206	RUNNING GEAR	Service		2.0				1	E
		Repair		2.0				1, 10	
		Replace		18.0				1	
0405020601	TIRES	Inspect	0.5						E
		Repair				1.0		10	
		Replace				1.0		10	
04050207	SUPPORT TOWER	Inspect	0.5						E
		Service	1.0						E
		Repair			2.0			10	
		Replace			6.0			10	
04050208	TOWER RAISING ASSEMBLY	Inspect	0.5						E
		Repair			1.0			10	
		Replace			3.0			10	
04050209	ENCLOSURE	Inspect	0.5						E
		Repair			2.0			10	
		Replace			6.0			10	
0406	OFFSHORE ANCHOR	Clean	1.0						E
		Inspect	1.0						E

Table 1. MAC for Modular Causeway System. (MCS) (Continued)

(1) GROUP NO.	(2) COMPONENT/ASSEMBLY	(3) MAINTENANCE FUNCTION	(4) MAINTENANCE LEVEL					(5) TOOLS AND EQUIP REF CODE	(6) REMARKS CODE
			UNIT		DS	GS	DEPOT		
			C	O	F	H	D		
0406	OFFSHORE ANCHOR (CONT'D)	Repair			4.0			7	
		Replace		2.0				1	
0407	ONSHORE ANCHOR	Clean	1.0						E
		Inspect	1.0						E
		Repair			4.0			7	
	CONTAINERS	Replace		2.0				1	
0408		Clean	1.0						E
		Inspect	2.0						E
		Repair			4.0			7	
		Replace					8.0		

Table 2. Tools and Test Equipment for Modular Causeway System. (MCS)

TOOL OR TEST EQUIPMENT REF CODE	MAINTENANCE LEVEL	NOMENCLATURE	NATIONAL STOCK NUMBER	TOOL NUMBER
1	O	General Mechanics Rail and Marine Tool Kit	5180-00-629-9783	
2	O	Torque Wrench, 30-150 in. lbs 3/8 in. Drive	5120-00-230-6380	
3	O	Torque Wrench, 30-150 ft lbs 1/2 in. Drive	5120-00-247-2540	
4	D	Torque Wrench, 100-500 ft lbs	5120-00-542-5577	
5	D	Pinch Pry Bar 60	5120-00-224-1384	
6	D	Hammer, Hand, (sledge hammer) 10 lb	5120-00-251-4489	
7	D	General Mechanics Tool Kit	5180-00-177-7033	
8	O	Hammer, Hand, Scaling	5120-00-224-4111	
9	O	Wire Brush	7920-00-291-5815	

■ **Table 2. Tools and Test Equipment for Modular Causeway System. (MCS) (Continued)**

TOOL OR TEST EQUIPMENT REF CODE	MAINTENANCE LEVEL	NOMENCLATURE	NATIONAL STOCK NUMBER	TOOL NUMBER
10	D	Automotive Tool Kit	5810-00-177-7033	
11	O	Wrench, Strap	5120-00-776-1840	
12	D	Wrench, Monkey	5120-00-277-3120	
13	D	Tester, Antifreeze Solution	6630-00-105-1418	
14	O	Fuse Puller and Tester	5120-00-319-3295	
15	O	Multimeter	6625-01-262-4815	
16	O	Welder Tool Kit	5180-00-754-0661	
17	D	Dial Indicator	5120-00-402-9619	
18	D	Thermometer, Test	6685-00-056-3109	
19	G	Wheel Puller		
20	D	Pliers, Snap Ring		
21	D	Tool Kit, Compressor	5180-01-267-2907	
22		Deleted	Deleted	
23	O	Blast Cleaning Machine (Power Washer)	4940-00-168-2173	
24	O	Scraper, Long Handle		
25	O	Air Tester		
26	O	Air Compressor		
27	D	Adaptor (1 5/8 in. Dia plugs) (Cylinder Block)		J21850
28	D	Aftercooler Adaptor Cup Plug Installer		J28711
29	D	Aftercooler Adaptor Plug Remover and Installer		J25275
30	D	Aftercooler Cup Plug Installer (2 1/2 in. Dia)		J24597
31	D	Alignment Tool		J21799
32	D	Block Assembly Wrench Set		J25451-B
33	D	Block Thread Repair Kit		J29513

■ **Table 2. Tools and Test Equipment for Modular Causeway System. (MCS) (Continued)**

TOOL OR TEST EQUIPMENT REF CODE	MAINTENANCE LEVEL	NOMENCLATURE	NATIONAL STOCK NUMBER	TOOL NUMBER
34	D	Cup Plug Installer (1 in. Dia)		J33420
35	D	Cylinder Block Air Box Plugging Tool		J29571
36	D	Cylinder Block Line Boring Tool		J29005
37	D	Cylinder Block Tap		J25384
38	D	Cylinder Diameter Checking Gage		J5347-B
39	D	Cylinder Hone Set (2½ in. to 5¾ in.)		J5902-01
40	D	Dial Bore Gage Master Setting Fixture		J23059-01
41	D	Dial Indicator Set		J22273-01
42	D	Diesel Engine Parts Dolly		J6387
43	D	Handle		J7079-02
44	D	Loctite "Chisel" Gasket Remover		PT7275
45	D	Master Ring Gage for Block Bore		J24564
46	D	Overhaul Stand (6V and 8V engines)		J29109
47	D	Overhaul Stand (12V and 16V engines)		J9384-04
48	D	Overhaul Stand Adaptor (6V and 8V engines)		J33850
49	D	Overhaul Stand Adaptor (12V and 16V engines)		J8650
50	D	Pipe Plug Remover/Installer (1/8 in. Dia)		J34650
51	D	Special Plug Remover (dry cylinder block)		J21995-01
52	D	Special Plug Remover		J23019
53	D	Load Cell Kit, Cam Follower Roller Fixture (Cylinder Head)		J33421-25

■ **Table 2. Tools and Test Equipment for Modular Causeway System. (MCS) (Continued)**

TOOL OR TEST EQUIPMENT REF CODE	MAINTENANCE LEVEL	NOMENCLATURE	NATIONAL STOCK NUMBER	TOOL NUMBER
54	D	Cam Follower Service Fixture		J33421-A
55	D	Cylinder Head Bolt Hole Cleanout Tap		J25384
56	D	Cylinder Head Guide Studs (set of two)		J24748
57	D	Cylinder Head Holding Plate Set		J3087-01
58	D	Cylinder Head Lifting Fixture		J22062-01
59	D	Engine Barring Tool		J22582
60	D	Feeler Gage Set (.0015 in. to .015 in.)		J3172
61	D	Feeler Stock (.0015 in.)		J23185
62	D	Fuel Line Nut Wrench		J8932B
63	D	Injector Fuel Hole Brush		J8152
64	D	Pressure Checking Tool		J28454
65	D	Push Rod Remover (set of three)		J3092-01
66	D	Slide Hammer		J2619-01
67	D	Spring Tester		J22738-02
68	D	Valve Bridge Holding Fixture		J21772
69	D	Valve Bridge Gage Remover (broken)		J7453
70	D	Valve Bridge Guide Remover Set		J7091-01
71	D	Valve Bridge Guide Installer		J7482
72	D	Valve Guide Cleaner		J5437
73	D	Valve Guide Installer (machined)		J21520
74	D	Valve Guide Remover		J6569-A
75	D	Valve Seat Dial Gage		J8165-2
76	D	Valve Guide Oil Seal Installer		J35373
77	D	Valve Seat Grinder (Model VIP)		J7040-A

■ **Table 2. Tools and Test Equipment for Modular Causeway System. (MCS) (Continued)**

TOOL OR TEST EQUIPMENT REF CODE	MAINTENANCE LEVEL	NOMENCLATURE	NATIONAL STOCK NUMBER	TOOL NUMBER
78	D	Valve Seat Grinder		J8165-1A
79	D	Valve Seat Grinder Adaptor Set		J24566
80	D	Valve Seat Insert Installer		J24357
81	D	Valve Seat Insert Remover Assembly		J23479-492
82	D	Valve Seat Insert Remover Collet		J23479-33
83	D	Valve Spring Checking Gage		J25076-B
84	D	Valve Spring Compressor		J7455-A
85	D	Water Nozzle Installer (intermediate)		J24857-A
86	D	Front Oil Seal Installer (6V and 8V) (Crankshaft)		J9783
87	D	Rear Oil Seal Installer (std and ovs seals)		J21112-B
88	D	Handle		J3154-A
89	D	Guide Studs (c/s with dowels)		J9727-2
90	D	Guide Studs (c/s without dowels)		J9727-5
91	D	Expander (std seal)		J4239
92	D	Handle		J8092
93	D	Guide Studs		J25002
94	D	Expander (ovs seal, no handle or guide studs)		J8682
95	D	Sleeve Installer (ovs seal)		J21983
96	D	Installer		J9727-A
97	D	Handle		J3154-1A
98	D	Expander (std seal, no handle)		J22425-A
99	D	Expander (ovs seal, no handle or guide studs)		J4195-01
100	D	Installer (ovs seal)		J4194-01

■ **Table 2. Tools and Test Equipment for Modular Causeway System. (MCS) (Continued)**

TOOL OR TEST EQUIPMENT REF CODE	MAINTENANCE LEVEL	NOMENCLATURE	NATIONAL STOCK NUMBER	TOOL NUMBER
101	D	Dial Indicator Set		J5959-01
102	D	Engine Barring Tool		J22582
103	D	Flywheel Housing Alignment Studs		J1927-01
104	D	Micrometer Ball Attachment		J4757
105	D	Torque Wrench Adaptor (12V and 16V engines)		J22898-A
106	D	Universal Bar Type Puller		J24420-B
107	D	Flywheel Lifting Fixture (Flywheel)		J25026
108	D	Flywheel Lifting Tool		J6361-01
109	D	Oil Seal Removing and Replacing Tool Set		J3154-04
110	D	Slide Hammer Set		J5901-01
111	D	Flywheel Housing Aligning Studs (set of four) (Flywheel Housing)		J1927-01
112	D	Flywheel Housing Concentricity Gage Set		J9734-C
113	D	Connecting Rod Holding Fixture (Piston, Connecting Rod and Cylinder Liner)		J7632
114	D	Cylinder Liner Master Ring Gage		J24564
115	D	Cylinder Hone Set (2½ in. to 5¾ in. range)		J5902-01
116	D	Cylinder Liner Hold-Down Tool		J24565-02
117	D	Cylinder Liner Remover Set		J24563-A
118	D	Dial Bore Gage Setting Fixture		J23059-01
119	D	Dial Indicator Set		J24898
120	D	Feeler Gage Set		J3172
121	D	Micrometer Ball Attachment		J4757

■ **Table 2. Tools and Test Equipment for Modular Causeway System. (MCS) (Continued)**

TOOL OR TEST EQUIPMENT REF CODE	MAINTENANCE LEVEL	NOMENCLATURE	NATIONAL STOCK NUMBER	TOOL NUMBER
122	D	Piston Crown Identification Gage		J25397-A
123	D	Piston Pin Alignment Tool		J24285
124	D	Piston Pin Retainer Installer		J23762-A
125	D	Piston Pin Retainer Leak Detector (plastic)		J23987-B
126	D	Deleted		Delete
127	D	Piston Ring Compressor		J24227
128	D	Piston Ring Remover Installer		J8128
129	D	Piston to Liner Feeler Gage Set		J5438-01
130	D	Seal Ring Compressor		J24226
131	D	Accessory Drive Hub Oil Seal Aligning Tool (Camshaft)		J21166
132	D	Alternator Drive Step-Up Gear Aligning Gage		J29893
133	D	Balance Weight Cover Oil Seal Installer		J9791
134	D	Camshaft Gear Puller		J1902-B
135	D	Camshaft Gear Puller Adaptor Plate Set		J6202-01
136	D	Camshaft and Oil Pump Gear Installer		J1903
137	D	Dial Indicator and Attachment Set		J5959-01
138	D	Puller Adaptor		J7932
139	D	Slide Hammer Set		J6471-02
140	D	Spring Scale		J8129
141	D	Universal Bar Type Puller		J24420-B
142	D	Pullers (Fuel & Governors)		J6270-1
143	D	Oil Seal Remover and Installer		J6270-3
144	D	Buffing Wheel (brass wire)		J7944

■ **Table 2. Tools and Test Equipment for Modular Causeway System. (MCS) (Continued)**

TOOL OR TEST EQUIPMENT REF CODE	MAINTENANCE LEVEL	NOMENCLATURE	NATIONAL STOCK NUMBER	TOOL NUMBER
145	D	Fuel Pipe Socket		J8932-B
146	D	Fuel System Primer		J5956
147	D	Injector Auxiliary Tester		J22640-A
148	D	Injector Body Reamer		J21089
149	D	Injector Calibrator		J22410
150	D	Injector Carbon Remover Set		J9418
151	D	Injector Holding Fixture		J22396
152	D	Injector Nut Seal Ring Installer		J29197
153	D	Injector Service Tool Set		J23435-C
154	D	Body Brush		J8152
155	D	Nut Socket Wrench		J4983-01
156	D	Rack Hole Brush		J8150
157	D	Spray Hole Cleaner Vice		J4298-1
158	D	Spray Tip Carbon Remover (high sack)		J9464-01
159	D	Spray Tip Carbon Remover (low sack)		J24838
160	D	Spray Tip Driver and Brushing Cleaner		J129101
161	D	Wire Sharpening Stone		J8170
162	D	Injector Tag Remover and Installer		J24767
163	D	Injector Test Oil (5, 10, 30 and 55 GAL)		J26400
164	D	Injector Tester		J23010-B
165	D	DDEC Injector Adaptor Kit		J23010-500
166	D	Lapping Block Set		J22090-A
167	D	Master Injector Calibrating Kit		J35369
168	D	Needle Valve Lift Gage		J9462-02

■ **Table 2. Tools and Test Equipment for Modular Causeway System. (MCS) (Continued)**

TOOL OR TEST EQUIPMENT REF CODE	MAINTENANCE LEVEL	NOMENCLATURE	NATIONAL STOCK NUMBER	TOOL NUMBER
169	D	Polishing Compound		J23038
170	D	Polishing Stick Set		J22964
171	D	Spray Tip Cleaning Wire (.007 in. Dia holes)		J21462-01
172	D	Spray Tip Flow Gage		J25600-B
173	D	Field Modification Kit		J25600-103
174	D	Spring Tester		J29196
175	D	Tip Conical. Gage and Rack Freeness Tester		J29584
176	D	Cylinder Head Holding Plate Set		J3087-01
177	D	Cylinder Liner Depth Gage		J22273-01
178	D	Injector Protrusion Gage		J25521
179	D	Injector Tube Service Tool Set		J22525-B
180	D	Injector Tube Swaging Tool		J28611-A
181	D	Fuel Pump Tool Set		J1508-E
182	D	Fuel Pump Wrench		J4242
183	D	Control Link Operating Lever Bearing Remover and Installer		J8985
184	D	Governor Cover Bearing Installer		J21068
185	D	Governor Cover Bearing Remover and Installer		J21967-01
186	D	High Speed Spring Retainer and Installer		J5345-12
187	D	Governor Weight Shaft Retaining Ring Installer		J36840
188	D	Blower Alignment Tool (Air System)		J33001
189	D	Blower Clearance Feeler Set		J1698-02
190	D	Blower Service Tool Set		J6270-G

■ **Table 2. Tools and Test Equipment for Modular Causeway System. (MCS) (Continued)**

TOOL OR TEST EQUIPMENT REF CODE	MAINTENANCE LEVEL	NOMENCLATURE	NATIONAL STOCK NUMBER	TOOL NUMBER
191	D	Installer, Lip Type Oil Seal/Water Sleeve		J35787-A
192	D	Dial Indicator Set (magnetic base)		J7872
193	D	Turbocharger Inlet Shield		J26554-A
194	D	Adaptor Cup Plug Installer		J28711
195	D	Adaptor Plug Remover and Installer		J25275
196	D	Bar Type Gear Puller (Lubrication System)		J24420
197	D	Oil Pump Drive Gear Installer (16V)		J9380
198	D	Oil Pump Drive Shaft Gear Installer (6V and 8V)		J22397
199	D	Oil Pump Driven Gear Installer (16V)		J9381
200	D	Oil Pump Driven Shaft Gear Installer (6V and 8V)		J22398
201	D	Oil Pump Driving Gear Installer (6V and 8V)		J22285
202	D	Spring Tester (1-125 lbs)		J29196
203	D	Strap Wrench (spin-on filter)		J24783
204	D	Cooling System Radiator Cap Pressure Tester (Cooling System)		J24460-01
205	D	Fingers, Fan Hub Nut Socket (16V)		J6534-8
206	D	Handle		J7079-2
207	D	Oil Seal Installer		J8501
208	D	Pliers		J4646
209	D	Puller		J24420-A
210	D	Socket, Fan Hub Nut (16V)		J22556-2
211	D	Thermostat Seal Installer		J8550

■ **Table 2. Tools and Test Equipment for Modular Causeway System. (MCS) (Continued)**

TOOL OR TEST EQUIPMENT REF CODE	MAINTENANCE LEVEL	NOMENCLATURE	NATIONAL STOCK NUMBER	TOOL NUMBER
212	D	Water Pump Bearing and Gear Installer		J25257
213	D	Water Pump Impeller/Gear Slip Torque Tool		J33765
214	D	Water Pump Seal Remover Set		J22150-B
215	D	Water Pump Impeller Slip Checking Fixture		J34034
216	D	Slide Hammer (Electrical Equipment)		J23907-1
217	D	Tachometer Drive Alignment Tool Set		J23068
218	D	Tachometer Drive Shaft Remover		J5901-3
219	O	Coveralls, Eye Protection, Respirator, Gloves (Zodiac Boat Hull)		
220	O	Grease Pencil Or Chalk		
221	O	Saber Saw With Metal Cutting Blades		
222	D	Grinder or Disc Sander w/ Coarse Medium Grit		
223	O	Measuring Tape		
224	D	Scissors, Shears		
225	O	Cardboard, Kraft Paper		
226	D	Disposable Containers, Mixing Sticks		
227	D	Disposable Brushes, Putty Knife		
228	D	Polyethylene Sheet		
229	D	Heavy Cardboard, Thin Plywood, Sheet Metal		
230	D	Acetone		

Table 3. Remarks for Modular Causeway System. (MCS)

REMARKS CODE	REMARKS
A	See MAC Chart for Causeway Ferry Diesel Engine Group Number 0101010101.
B	See MAC Chart for Causeway Ferry Marine Gear Group Number 0101010102.
C	See MAC Chart for Causeway Ferry Marine Gear Group Number 0101010103.
D	All repairs to the pump-jet must be done at depot level due to lack of technical information provided by the manufacturer, Schottel of Germany.
E	Preventive Maintenance Checks and Services (PMCS).
F	Includes replacement of level sensors, pump and motor.
G	Most work needs to be done by an authorized manufacturer's technical representative.
H	Refer to Army Technical Manual TM 11-5820-890-10-8.
I	Refer to Army Technical Manual TM 11-5825-291-13.
J	Includes cylinder liner, crankcase, crankcase breather and engine mounts.
K	Includes valves, springs, rocker arm, push rods, etc.
L	Includes valves, main bearings, vibration damper and crankshaft pulley.
M	Includes drive shaft flex coupling.
N	Includes rings, connecting rod and connecting rod bearings.
O	Includes gear train, camshaft, idler gear, idler gear bearing, crankshaft timing gear, blower drive gear, and front and rear accessory drive gears.
P	Includes fuel water separator, fuel lines, fuel filter/strainer, fuel cooler, fuel manifold, fuel injector, fuel injector tube and valves.
Q	Includes air shutdown housing and air box check valves.
R	Includes intercooler and after cooler.
S	Includes lube oil pump driving gear, lube oil pressure regulator, lube oil relief valves, lube oil filter by-pass valve, lube oil cooler by-pass valve, lube oil pan and lube oil ventilation system.
T	Includes fresh water manifold and thermostat.
U	Includes raw water duplex strainer.
V	Includes starting batteries.
W	Rebuild of the marine gear is a depot level function.
X	Includes oil filter screen, pressure gage, temperature gage, selector valve, oil pump drive, output seal and gear mounts.

Table 3. Remarks for Modular Causeway System. (MCS) (Continued)

REMARKS CODE	REMARKS
Y	Rebuild of the transfer case is a depot level function.
Z	See MAC Chart for Modular Warping Tug Diesel Engine Group Number 0301010101.
AA	See MAC Chart for Modular Warping Tug Marine Gear Group Number 0301010102.
AB	See MAC Chart for Modular Warping Tug Transfer Case Group Number 0301010103.
AC	Refer to Army Technical Manual TM 55-3950-204-14 & P.
AD	Refer to Army Technical Manual TM 5-2815-258-10.
AE	Refer to Army Technical Manual TM 55-1925-257-14&P.

**UNIT, DIRECT SUPPORT AND GENERAL SUPPORT MAINTENANCE
WARPING TUG
TRANSFER CASE
EXPENDABLE AND DURABLE ITEMS LIST (EDIL)**

INTRODUCTION

Scope

This work package lists expendable and durable items that you will need to operate and maintain the warping tug transfer case. This list is for information only and is not authority to requisition the listed items. These items are authorized to you by CTA 50-970, Expendable/Durable Items (Except Medical, Class V Repair Parts, and Heraldic Items), or CTA 8-100 Army Medical Department Expendable/Durable Items.

Explanation of Columns in the Expendable / Durable Items List

Column (1) - Item Number. This number is assigned to the entry in the listing and is referenced in the narrative instructions to identify the item. (e.g., Use cleaner (Item 3, WP 0029 00)).

Column (2) - Level. This column identifies the lowest level of maintenance that requires the listed item. (C = Operator/Crew, O = Unit, F = Direct Support, H = General Support, D = Depot)

Column (3) - National Stock Number. This is the NSN assigned to the item you can use to requisition it.

Column (4) - Item Name, Description, Commercial and Government Entity Code (CAGEC) and Part Number (PN). This column provides the other information you need to identify the item.

Column (5) - Unit of Measure (U/M). This code shows the physical measurement or count of an item, such as gallon, dozen, gross, etc.

EXPENDABLE AND DURABLE ITEMS LIST

Table 1. Expendables and Durable List. (EDIL)

(1) ITEM NUMBER	(2) LEVEL	(3) NATIONAL STOCK NUMBER	(4) ITEM NAME, DESCRIPTION, CAGE AND PART NUMBER	(5) U/M
1	O	8030-00-251-3980	Antisieze Compound, 1 lb can thread compound (81349) MIL-A-907	QT
2	O	8105-01-459-3962	Bag, Plastic, 8 in. X 10 in., clear plastic (8C914) 2110R	PKG
3	O	6850-01-431-9025	Cleaner, Type II, 50 lb container (81349) MIL-C-29602	CO
4	O	7920-00-044-9281	Cloth, Cleaning, contains 10 lbs, white, 12 in. X 16 in. (58536) A-A-59323	BX
5	O	9150-00-186-6681	Lubricating Oil, Engine, 5 gallon can, internal combustion engine, MIL-L-2104, 30 Grade (81349) M2104-1-30W	QT

Table 1. Expendables and Durable List. (EDIL) (Continued)

(1) ITEM NUMBER	(2) LEVEL	(3) NATIONAL STOCK NUMBER	(4) ITEM NAME, DESCRIPTION, CAGE AND PART NUMBER	(5) U/M
6	O	4235-01-416-8465	Spill Clean-Up Kit, Hazardous Material, sorbent pads with disposal bags used for petroleum spills (50378) P-SKFL31	KT
7	F	8135-00-952-0672	Tags, Shipping, red with metal eyelet patch, 2.375 in. X 4.750 in. (58536) A-A-900	HD
8	F	8135-00-178-9192	Tags, Shipping, yellow with metal eyelet patch, 3.063 in. X 6.188 in. (58536) A-A-1266	HD
9	O	8030-00-889-3535	Tape, Antiseize, white, 0.50 in. wide X 260 in. long X .0035 in. thick (58536) AA50892-2-2	RL
10	O	5510-00-268-3476	Wedge, Wood, shoring wedge, Type B1, 3 in. wide X 1.5 in. tall X 12 in. long (80064) S8800-461043	EA

**UNIT, DIRECT SUPPORT AND GENERAL SUPPORT MAINTENANCE
WARPING TUG
TRANSFER CASE
TOOL IDENTIFICATION LIST**

INTRODUCTION**Scope**

This work package lists all common tools, supplements and special tools/fixtures needed to maintain the warping tug transfer case.

Explanation of Columns in the Tool Identification List

Column (1) - Item Number. This number is assigned to the entry in the list and is referenced in the initial setup to identify the item (e.g., Crowbar (Item 3, WP 0030 00)).

Column (2) - Item Name. This column lists the item by noun nomenclature and descriptive features (e.g. Apron, utility).

Column (3) - National Stock Number. This is the National Stock Number (NSN) assigned to the item; use it to requisition the item.

Column (4) - Part Number/CAGEC. Indicates the primary number used by the manufacturer (individual, company, firm, corporation or government activity) which controls design and characteristics of the item by means of its engineering drawings, specifications, standards and inspection requirements to identify an item or range of items. The manufacturers Commercial and Government Entity Code (CAGEC) is also included.

Column (5) - Reference. This column identifies the authorizing supply catalog or RPSTL for items listed in this work package.

TOOL IDENTIFICATION LIST**Table 1. Tool Identification List. (TIL)**

(1) ITEM NO.	(2) ITEM NAME	(3) NATIONAL STOCK NUMBER	(4) PART NUMBER/ CAGEC	(5) REFERENCE
1	Apron, utility	8415-00-082-6108	A-A-55063 (58536)	SC 4910-95-A72
2	Brush, stencil (soft bristle)	7520-00-223-8000	A-A2903 (58536)	SC 4910-95-A72
3	Bushing driver set	5120-01-311-2041	A157C (55719)	
4	Crowbar	5120-00-224-1392	9150189 (18876)	SC 4910-95-A72
5	Gloves, chemical	8415-00-266-8677	ZZ-G-381 (81349)	
6	Gloves, men's and women's (leather palm)	8415-00-634-4658	37G2940 (90142)	

Table 1. Tool Identification List. (TIL) (Continued)

(1) ITEM NO.	(2) ITEM NAME	(3) NATIONAL STOCK NUMBER	(4) PART NUMBER/ CAGEC	(5) REFERENCE
7	Goggles, industrial	4240-00-190-6432	A-A-110 (58536)	SC 4910-95-A72
8	Hammer, hand	5120-00-357-6077	GGG-H-33 (81348)	
9	Pan, drain	4910-00-387-9592	MIL-P-45819 (81349)	SC 4910-95-A72
10	Press, arbor, hand operated	3444-00-243-2654	A-A-51199 (58536)	SC 4910-95-A68
11	Puller kit, universal	5180-00-423-1596	GGG-P-781 (81348)	SC 4910-95-A68
12	Sling, engine and transmission, motor vehicle	4910-01-243-5556	DFP-188 (59678)	SC 4910-95-A68
13	Tool kit, general mechanic's	5180-00-177-7033	SC5180-90-CL-N26 (50980)	SC 5180-90-N26
14	Tool kit, general mechanic's (rail and marine)	5180-00-629-9783	SC5180-90-CL-N55 (50980)	SC 5180-90-N55
15	Wrench, pipe, adj. jaw style 1 ½ cap., 14 in. lg	5120-00-277-1486	5120-00-277-1486 (83421)	SC 4910-95-A72
16	Wrench, torque (½ in., 0-150 ft lbs, 0-203.4 N-m)	5120-00-247-2540	J1313/03914 (33287)	SC 4910-95-A68
17	Wrench, torque (¾ in., 100 - 600 ft lbs, 135.6-813.6 N-m)	5120-01-113-9564	7379 (45225)	SC 4910-95-A72
18	Wrench, torque (½ in., 0-175 ft lbs, 0-237.3 N-m)	5120-01-396-5751	1753LDF (03194)	SC 4910-95-A68

INDEX

<u>Subject</u>	<u>WP Sequence No.– Page No.</u>
A	
Alphabetical Index	INDEX-1
B	
Bearing Cap Cover Gasket, Replacement	0023 00 001
Breather, Replacement	0016 00 001
C	
Cleaning	0012 00 001
D	
Description and Data	
Equipment Characteristics, Capabilities and Features	0002 00 001
Equipment Data	0004 00 001
Location and Description of Major Components	0003 00 001
E	
Equipment Characteristics, Capabilities and Features, Description and Data	0002 00 001
Equipment Data, Description and Data	0004 00 001
Expendable and Durable Items List (EDIL)	0029 00 001
G	
General Information	0001 00 001
H	
Hazardous Material Warning Icons	d
How To Use this Manual	iii
L	
List of Effective Pages/Work Packages	A
Location and Description of Major Components, Description and Data	0003 00 001
Lower Input Oil Seal, Replacement	0022 00 001
Lube Pump, Replacement	0017 00 001
M	
Maintenance Allocation Chart (MAC)	0028 00 001
Maintenance Allocation Chart (MAC), Introduction	0027 00 001
O	
Oil Cooler	
Lines, Replacement	0018 00 001
Replacement	0019 00 001
Oil Level Decreases In the Sump, Troubleshooting Procedures	0008 00 001
Oil Level Increases In the Sump, Troubleshooting Procedures	0007 00 001

INDEX (CONT'D)

<u>Subject</u>	<u>WP Sequence No. – Page No.</u>
P	
Preparation for Storage or Shipment	0024 00 001
Preventive Maintenance Checks and Services (PMCS)	
Introduction	0010 00 001
Lubrication Procedures	0011 00 001
R	
Rebuild	0015 00 001
References	0026 00 001
Removal and Installation	0014 00 001
S	
Safety Warning Icons	b
Service Upon Receipt	0009 00 001
Servicing	0013 00 001
T	
Theory of Operation	0005 00 001
Tool Identification List (TIL)	0030 00 001
Torque Limit Work Package	0025 00 001
Troubleshooting Procedures	
Oil Level Decreases In the Sump	0008 00 001
Oil Level Increases In the Sump	0007 00 001
Troubleshooting Procedures Index	0006 00 001
U	
Upper Input Oil Seal, Replacement	0020 00 001
Upper Output Oil Seal, Replacement	0021 00 001
W	
Warning Summary	a

These are the instructions for sending an electronic 2028.

The following format must be used if submitting an electronic 2028. The subject line must be exactly the same and all fields must be included; however, only the following fields are mandatory: 1, 3, 4, 5, 6, 7, 8, 9, 10, 13, 15, 16, 17 and 27.

From: "Whoever" whoever@avma27.army.mil
To: whoever@avma27.army.mil
To: TACOM-TECH-PUBS@ria.army.mil

Subject:DA Form 2028

1. **From:** Joe Smith
2. **Unit:** home
3. **Address:** 4300 Park
4. **City:** Hometown
5. **St:** MO
6. **Zip:** 77777
7. **Date Sent:** 19-OCT-93
8. **Pub no:** 55-1915-200-10
9. **Pub Title:** TM
10. **Publication Date:** 11-APR-88
11. **Change Number:** 12
12. **Submitter Rank:** MSG
13. **Submitter Fname:** Joe
14. **Submitter Mname:** T
15. **Submitter Lname:** Smith
16. **Submitter Phone:** 123-123-1234
17. **Problem:** 1
18. **Page:** 1
19. **Paragraph:** 3
20. **Line:** 4
21. **NSN:** 5
22. **Reference:** 6
23. **Figure:** 7
24. **Table:** 8
25. **Item:** 9
26. **Total:** 123
27. **Text:**

This is the text for the problem below line 27.

RECOMMENDED CHANGES TO PUBLICATIONS AND BLANK FORMS <small>For use of this form, see AF 25-32; the proponent agency is DAASA</small>						Use Part II (reverse) for Repair Parts and Special Tool Lists (RPSTL) and Supply Catalogs/Supply Manuals (SC/SM).	DATE
TO: <i>(Forward to proponent of publication or form) (Include ZIP Code)</i>						FROM: <i>(Activity and location) (Include ZIP Code)</i>	
PART I - ALL PUBLICATIONS (EXCEPT RPSTL AND SC/SM) AND BLANK FORMS							
PUBLICATION/FORM NUMBER						DATE	TITLE
ITEM	PAGE	PARA-GRAPH	LINE	FIGURE NO.	TABLE	RECOMMENDED CHANGES AND REASON	
<small>* Reference to line numbers within the paragraph or subparagraph.</small>							
TYPED NAME, GRADE OR TITLE						TELEPHONE EXCHANGE/AUTOVON, PLUS EXTENSION	SIGNATURE

TO: <i>(Forward direct to addressee listed in publication)</i>			FROM: <i>(Activity and location) (Include ZIP Code)</i>				DATE	
PART II - REPAIR PARTS AND SPECIAL TOOL LISTS AND SUPPLY CATALOGS/SUPPLY MANUALS								
PUBLICATION NUMBER				DATE			TITLE	
PAGE NO.	COLM NO.	LINE NO.	NATIONAL STOCK NUMBER	REFERENCE NO.	FIGURE NO.	ITEM NO.	TOTAL NO. OF MAJOR ITEMS SUPPORTED	RECOMMENDED ACTION
PART III - REMARKS <i>(Any general remarks or recommendations, or suggestions for improvement of publications and blank forms. Additional blank sheets may be used if more space is needed.)</i>								
TYPED NAME, GRADE OR TITLE				TELEPHONE EXCHANGE/AUTOVON. PLUS EXTENSION			SIGNATURE	

By Order of the Secretary of the Army:

PETER J. SCHOOMAKER
General, United States Army
Chief of Staff

Official:



JOEL B. HUDSON
Administrative Assistant to the
Secretary of the Army
0231304

To be distributed in accordance with the initial distribution number (IDN) 256759 requirements for TM 55-1945-205-24-3-4.

The Metric System and Equivalents

Linear Measure

1 centimeter = 10 millimeters = .39 inch
 1 decimeter = 10 centimeters = 3.94 inches
 1 meter = 10 decimeters = 39.37 inches
 1 dekameter = 10 meters = 32.8 feet
 1 hectometer = 10 dekameters = 328.08 feet
 1 kilometer = 10 hectometers = 3,280.8 feet

Weight

1 centigram = 10 milligrams = .15 grain
 1 decigram = 10 centigrams = 1.54 grains
 1 gram = 10 decigrams = .035 ounce
 1 dekagram = 10 grams = .35 ounce
 1 hectogram = 10 dekagrams = 3.52 ounces
 1 kilogram = 10 hectograms = 2.2 pounds
 1 quintal = 100 kilograms = 220.46 pounds
 1 metric ton = 10 quintals = 1.1 short tons

Liquid Measure

1 centiliter = 10 milliliters = .34 fl. ounce
 1 deciliter = 10 centiliters = 3.38 fl. ounces
 1 liter = 10 deciliters = 33.81 fl. ounces
 1 dekaliter = 10 liters = 2.64 gallons
 1 hectoliter = 10 dekaliters = 26.42 gallons
 1 kiloliter = 10 hectoliters = 264.18 gallons

Square Measure

1 sq. centimeter = 100 sq. millimeters = .155 sq. inch
 1 sq. decimeter = 100 sq. centimeters = 15.5 sq. inches
 1 sq. meter (centare) = 100 sq. decimeters = 10.76 sq. feet
 1 sq. dekameter (are) = 100 sq. meters = 1,076.4 sq. feet
 1 sq. hectometer (hectare) = 100 sq. dekameters = 2.47 acres
 1 sq. kilometer = 100 sq. hectometers = .386 sq. mile

Cubic Measure

1 cu. centimeter = 1000 cu. millimeters = .06 cu. inch
 1 cu. decimeter = 1000 cu. centimeters = 61.02 cu. inches
 1 cu. meter = 1000 cu. decimeters = 35.31 cu. feet

Approximate Conversion Factors

To change	To	Multiply by	To change	To	Multiply by
inches	centimeters	2.540	ounce-inches	newton-meters	.007062
feet	meters	.305	centimeters	inches	.394
yards	meters	.914	meters	feet	3.280
miles	kilometers	1.609	meters	yards	1.094
square inches	square centimeters	6.451	kilometers	miles	.621
square feet	square meters	.093	square centimeters	square inches	.155
square yards	square meters	.836	square meters	square feet	10.764
square miles	square kilometers	2.590	square meters	square yards	1.196
acres	square hectometers	.406	square kilometers	square miles	.386
cubic feet	cubic meters	.028	square hectometers	acres	2.471
cubic yards	cubic meters	.766	cubic meters	cubic feet	35.315
fluid ounces	milliliters	29.573	cubic meters	cubic yards	1.308
pints	liters	.473	milliliters	fluid ounces	.034
quarts	liters	.946	liters	pints	2.113
gallons	liters	3.785	liters	quarts	1.057
ounces	grams	28.349	liters	gallons	.264
pounds	kilograms	.454	grams	ounces	.035
short tons	metric tons	.907	kilograms	pounds	2.205
pound-feet	newton-meters	1.356	metric tons	short tons	1.102
pound-inches	newton-meters	11.296			

Temperature (Exact)

°F Fahrenheit temperature $\frac{5}{9}$ (after subtracting 32)

Celsius temperature °C

